

**POWERKEY ULTIMATE
Keypads**

CE  E6441



HORIZONTAL MOUNT

VERTICAL MOUNT

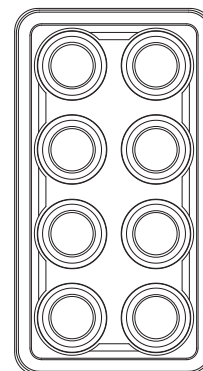
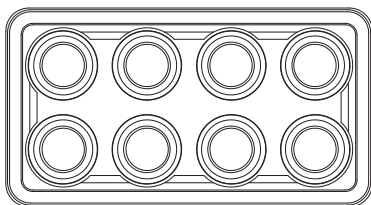

OVERVIEW

Specifications for safely mounting the PKU series keypads using the correct torque settings.

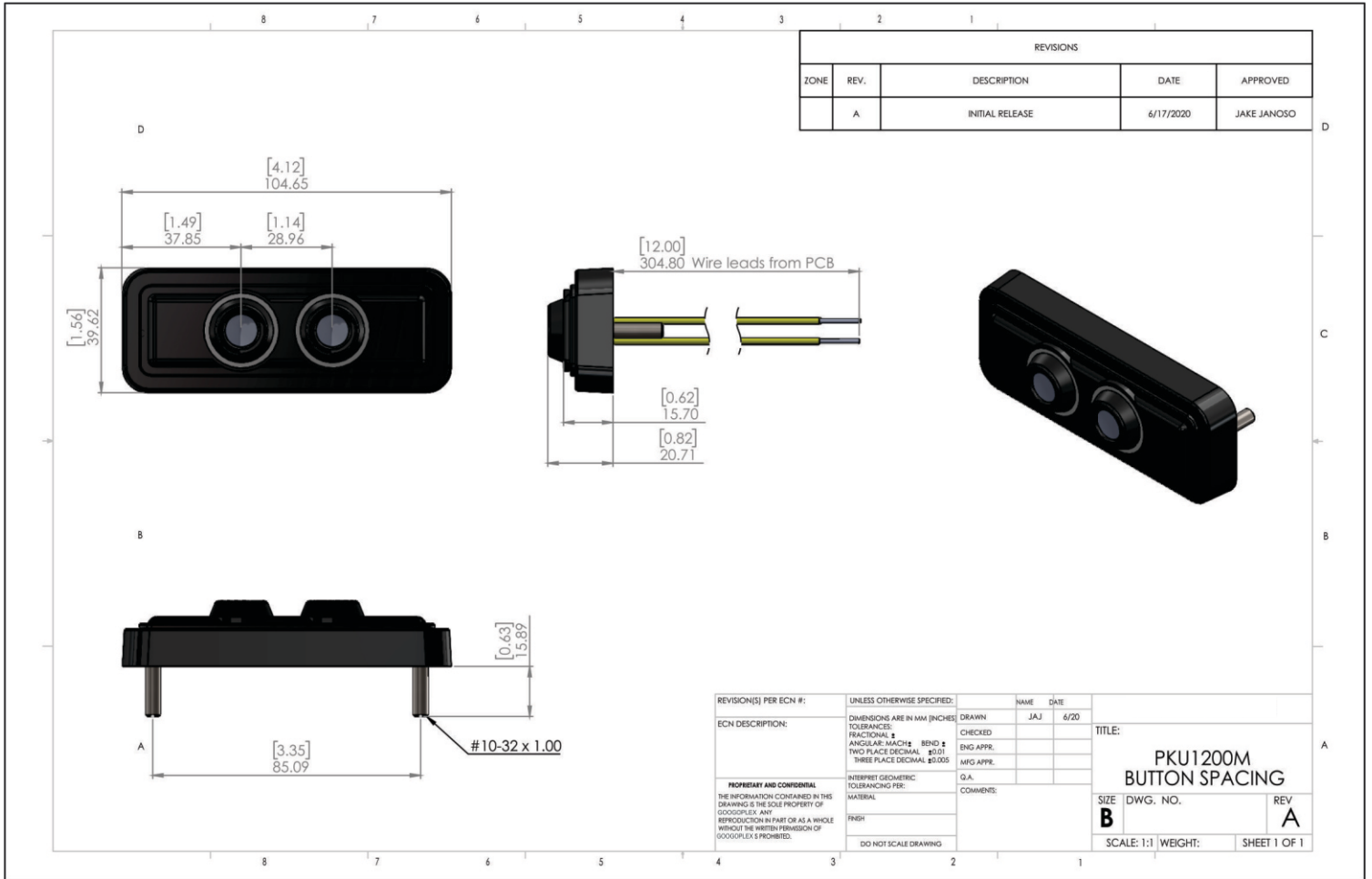

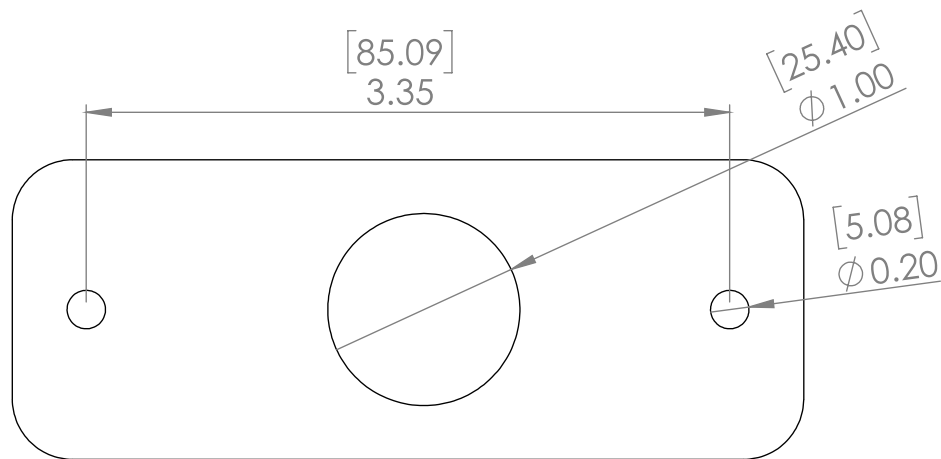

MOUNT ON A FLAT SURFACE ONLY

Part Number: GEC-PKU1200M

Nut Size*: 10-32 UNF S/S

Washer Sizes: M5 Spring Washer S/S, M5 Flat Washer S/S

Torque Maximum: 7 +/- 1 in. lbs

*** DO NOT USE NYLOC NUTS**

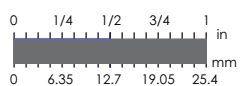

Increments are 1/16"
Scale 1:1

PLEASE VERIFY SCALING PRIOR TO DRILLING

Mounting Template Scale 1:1 (Units in inches (mm))

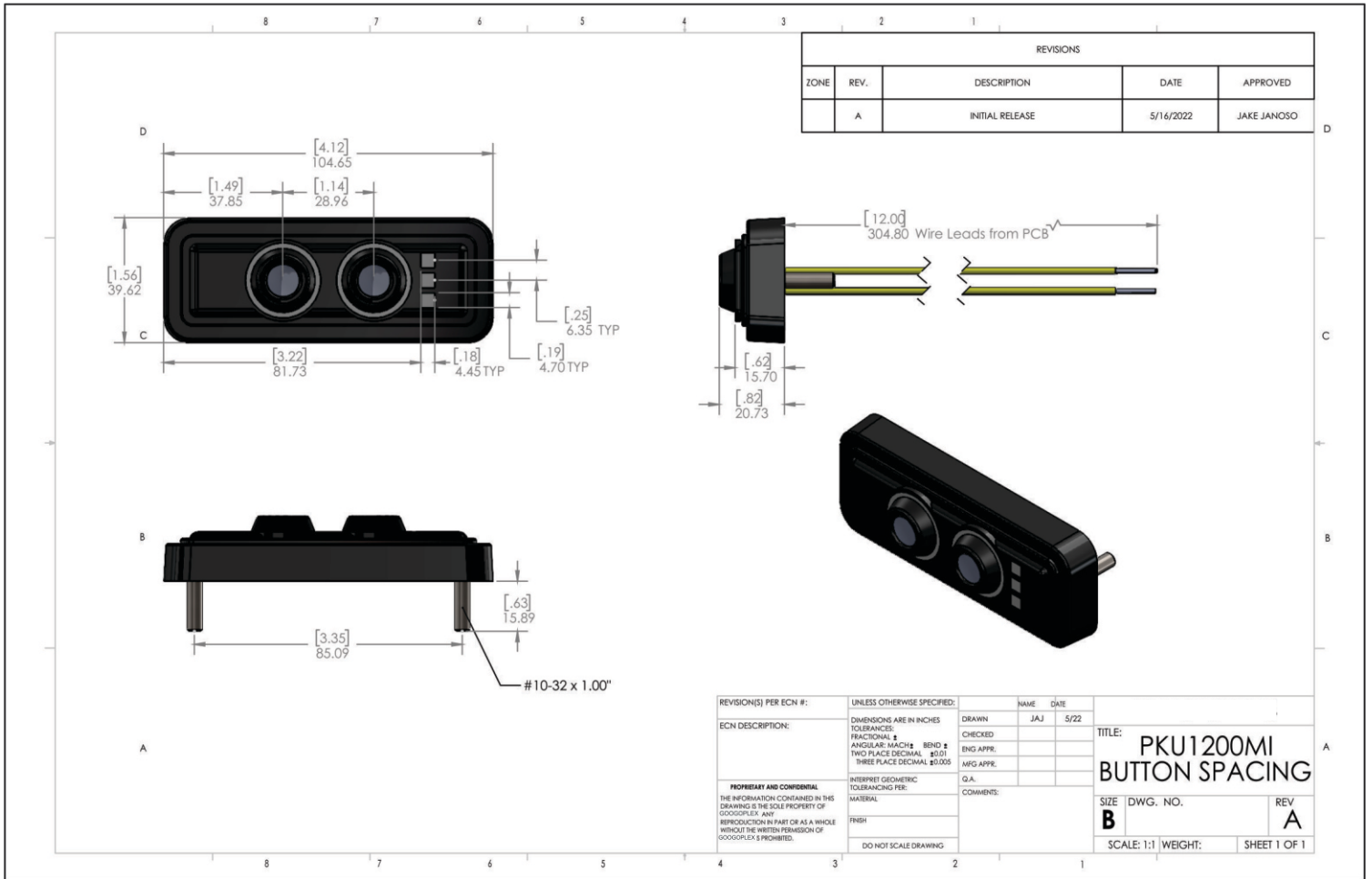

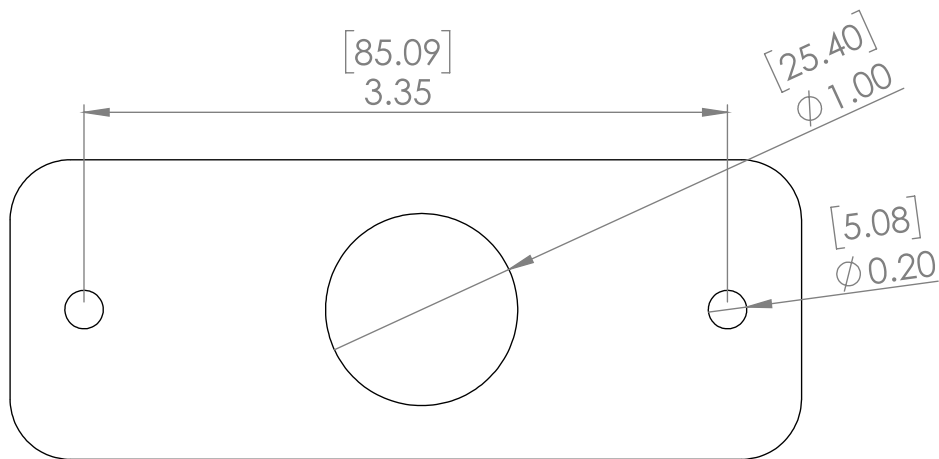

MOUNT ON A FLAT SURFACE ONLY

- Part Number: GEC-PKU1200MI
- Nut Size*: 10-32 UNF S/S
- Washer Sizes: M5 Spring Washer S/S, M5 Flat Washer S/S
- Torque Maximum: 7 +/- 1 in. lbs
- * DO NOT USE NYLOC NUTS**

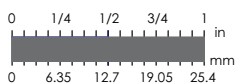

Increments are 1/16"
Scale 1:1

PLEASE VERIFY SCALING PRIOR TO DRILLING
Mounting Template Scale 1:1 (Units in inches (mm))

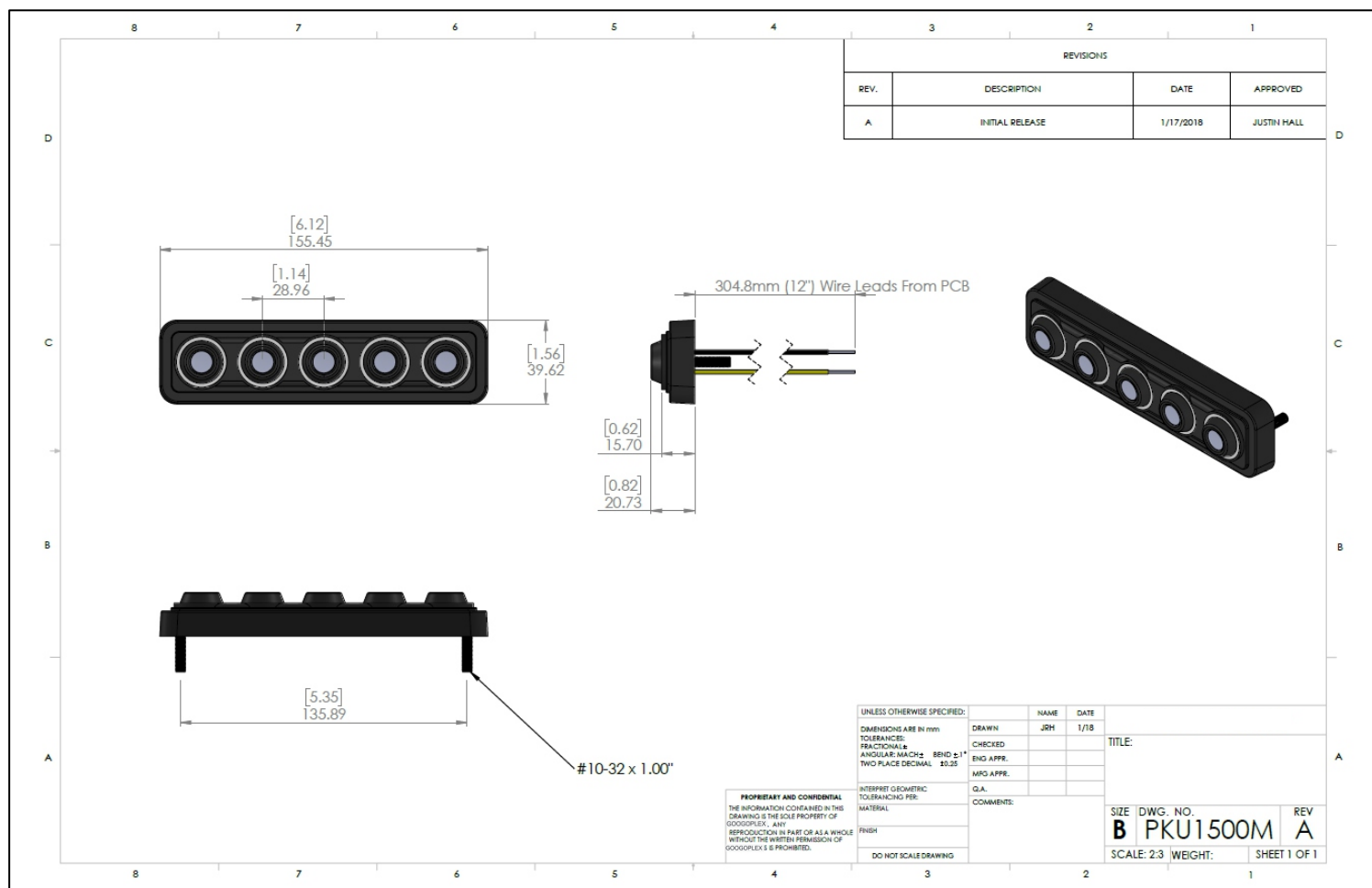

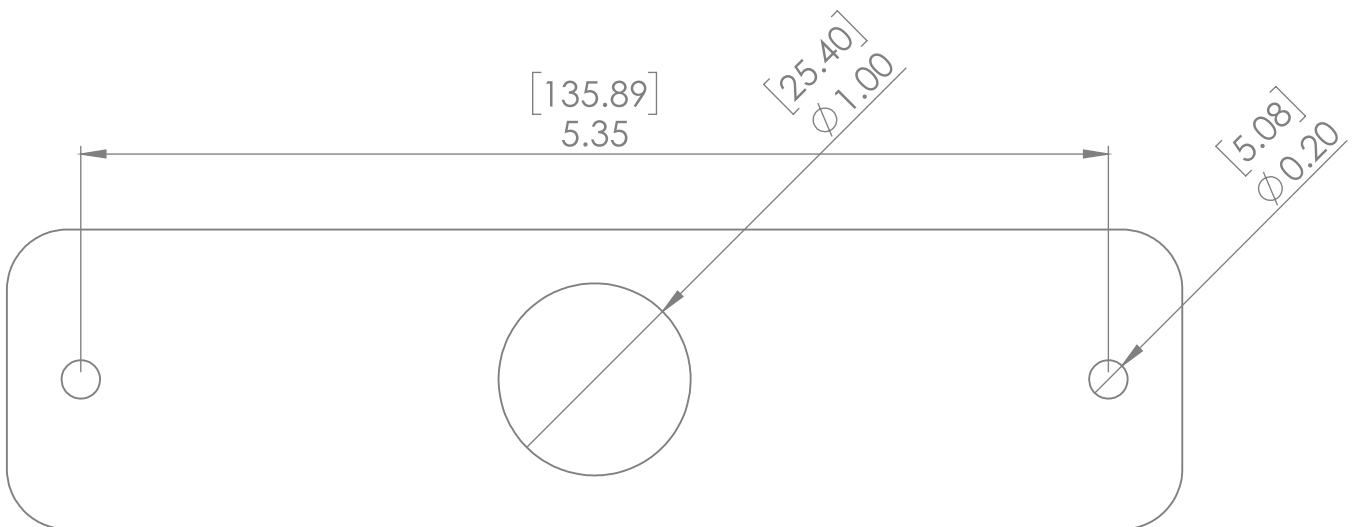

MOUNT ON A FLAT SURFACE ONLY

Part Number: GEC-PKU1500M

Nut Size*: 10-32 UNF S/S

Washer Sizes: M5 Spring Washer S/S, M5 Flat Washer S/S

Torque Maximum: 7 +/- 1 in. lbs

*** DO NOT USE NYLOC NUTS**

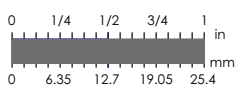

Increments are 1/16"
Scale 1:1

PLEASE VERIFY SCALING PRIOR TO DRILLING

Mounting Template Scale 1:1 (Units in inches (mm))

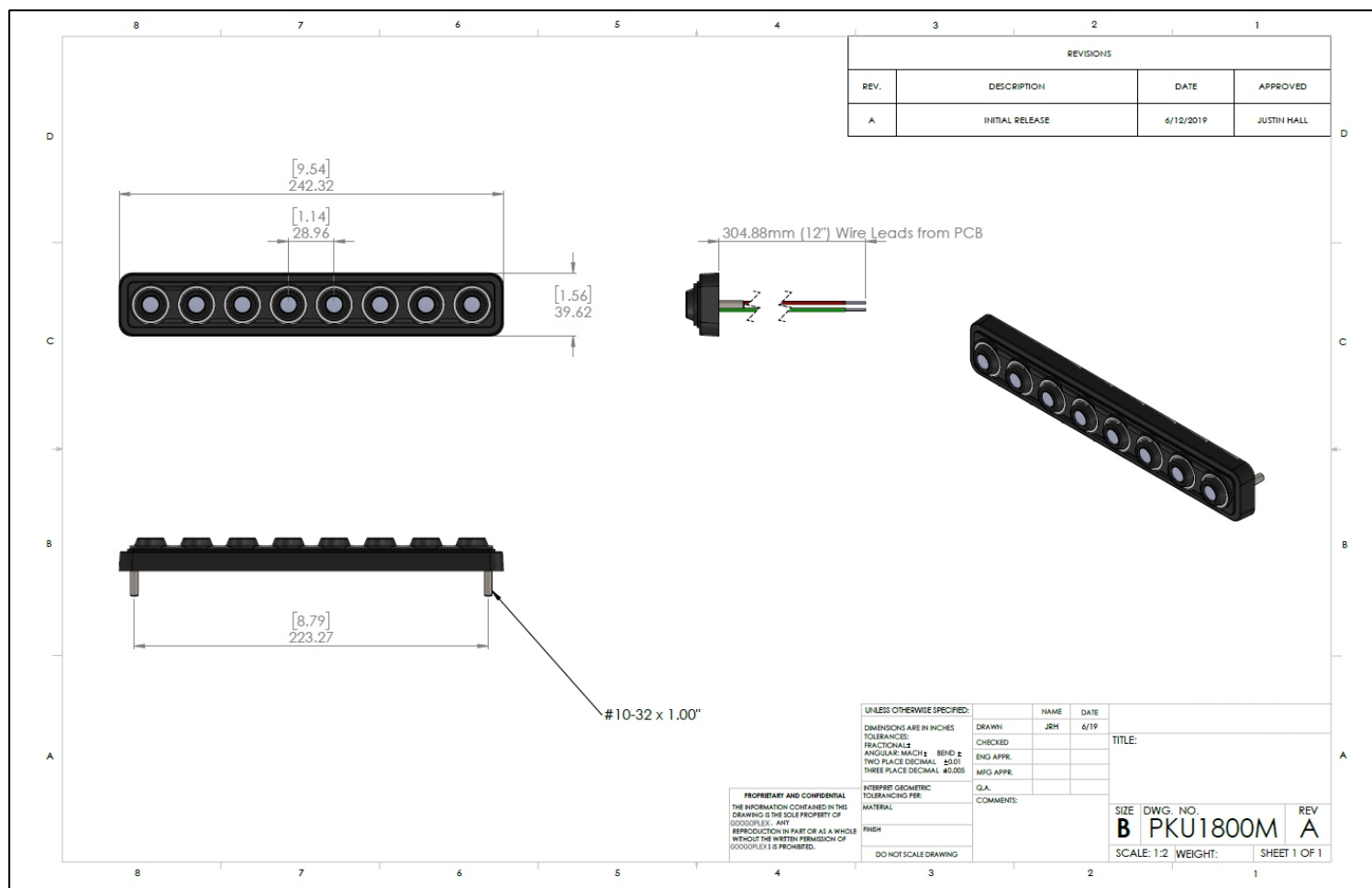



Mounting Template **PKU1800M**

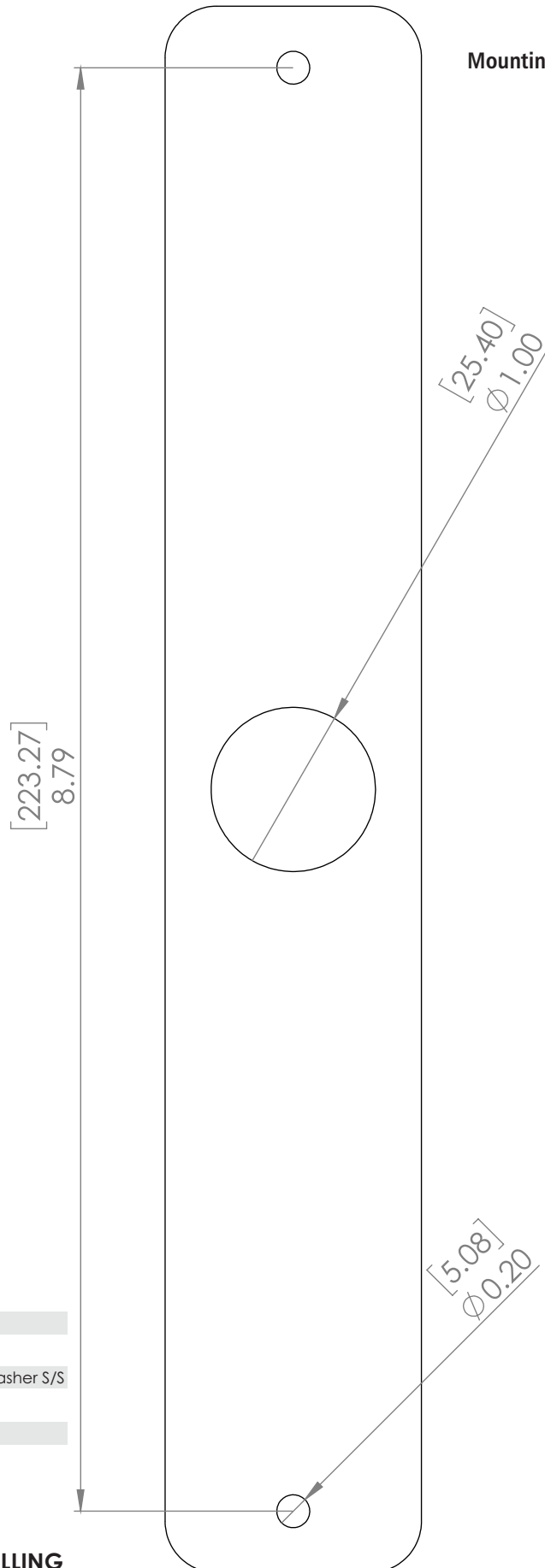

MOUNT ON A FLAT SURFACE ONLY

- Part Number: GEC-PKU1800M
- Nut Size*: 10-32 UNF S/S
- Washer Sizes: M5 Spring Washer S/S, M5 Flat Washer S/S
- Torque Maximum: 7 +/- 1 in. lbs
- * DO NOT USE NYLOC NUTS**

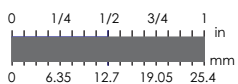

Increments are 1/16"
Scale 1:1

PLEASE VERIFY SCALING PRIOR TO DRILLING
Mounting Template Scale 1:1 (Units in inches (mm))

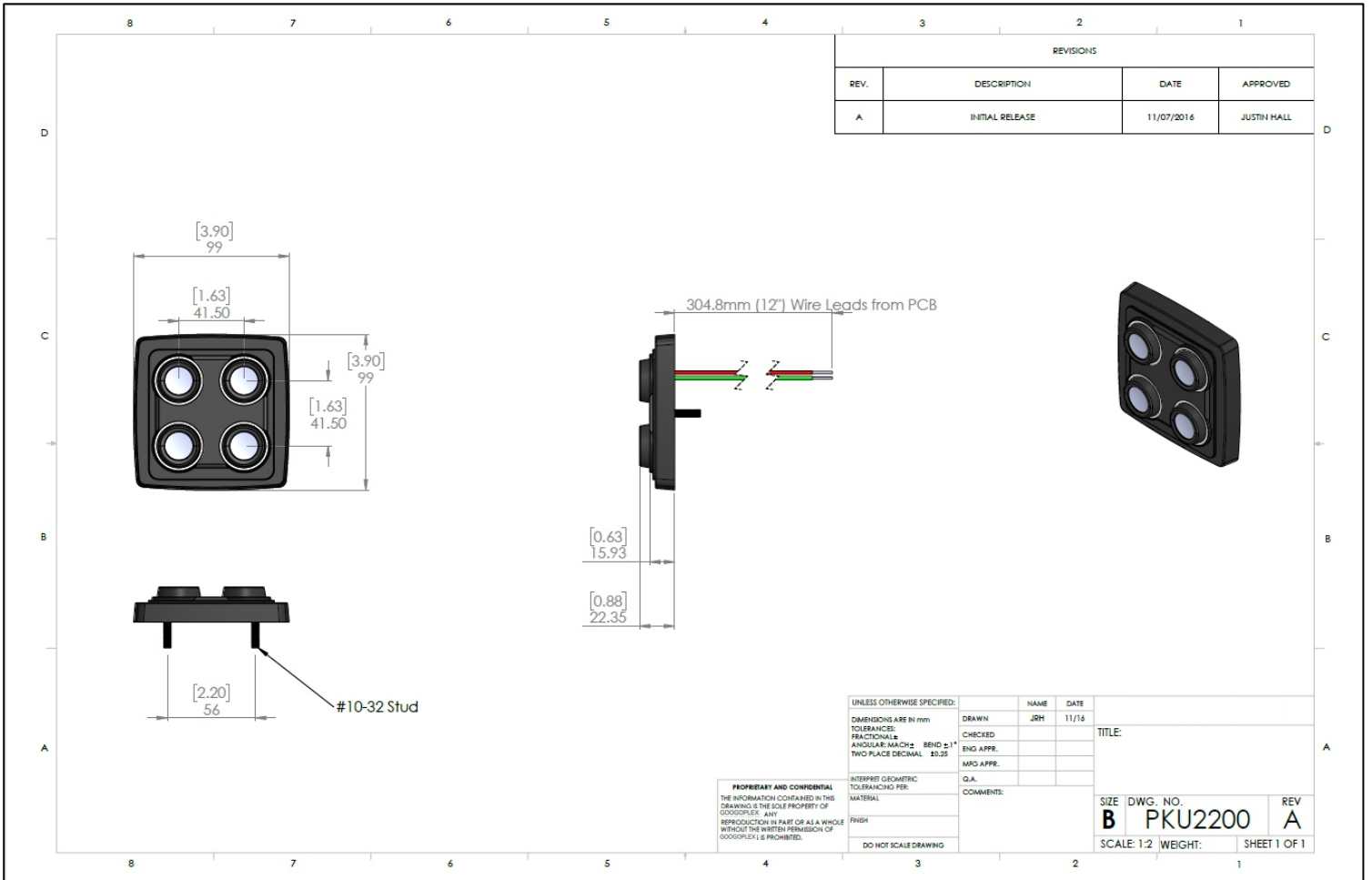

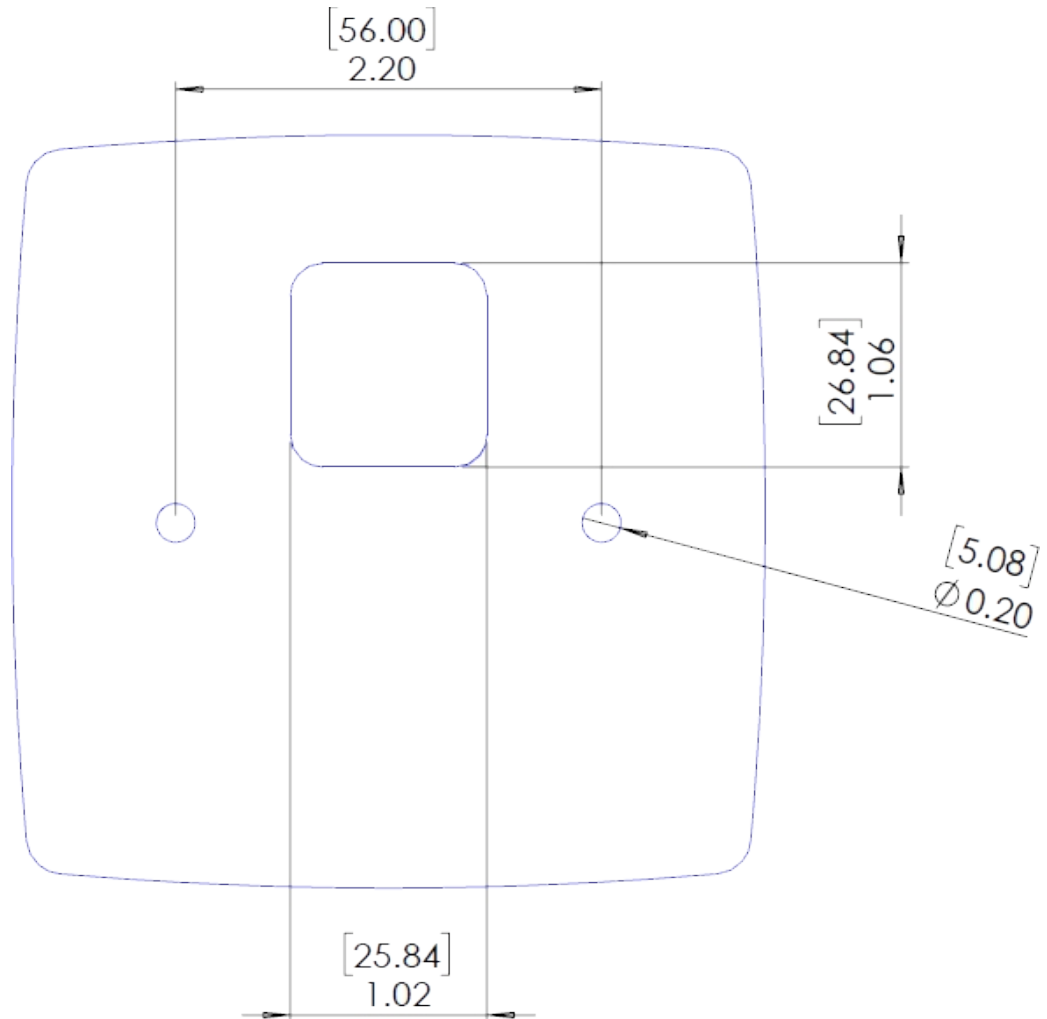

MOUNT ON A FLAT SURFACE ONLY

Part Number: GEC-PKU2200

Nut Size*: 10-32 UNF S/S

Washer Sizes: M5 Spring Washer S/S, M5 Flat Washer S/S

Torque Maximum: 7 +/- 1 in. lbs

*** DO NOT USE NYLOC NUTS**

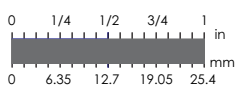

Increments are 1/16"
Scale 1:1

PLEASE VERIFY SCALING PRIOR TO DRILLING

Mounting Template Scale 1:1 (Units in inches (mm))

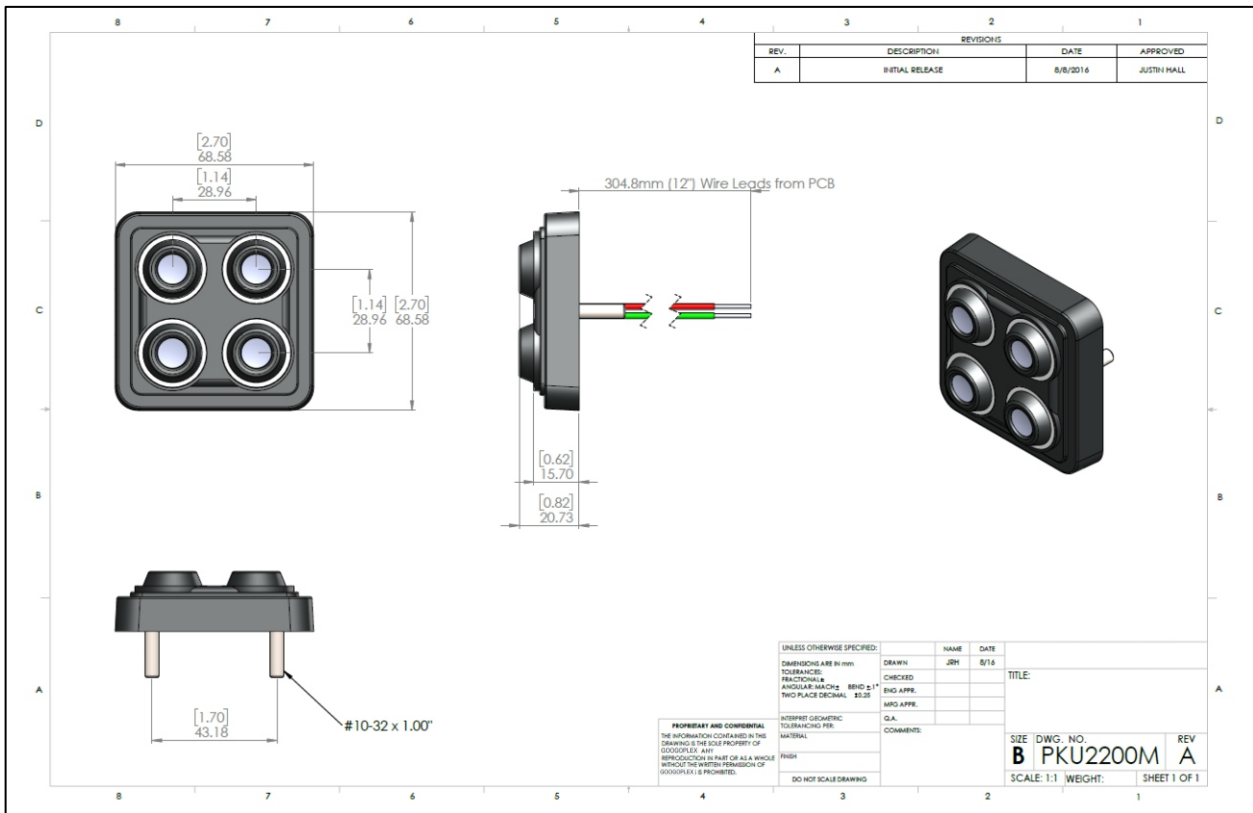

With Bezel Attachment:

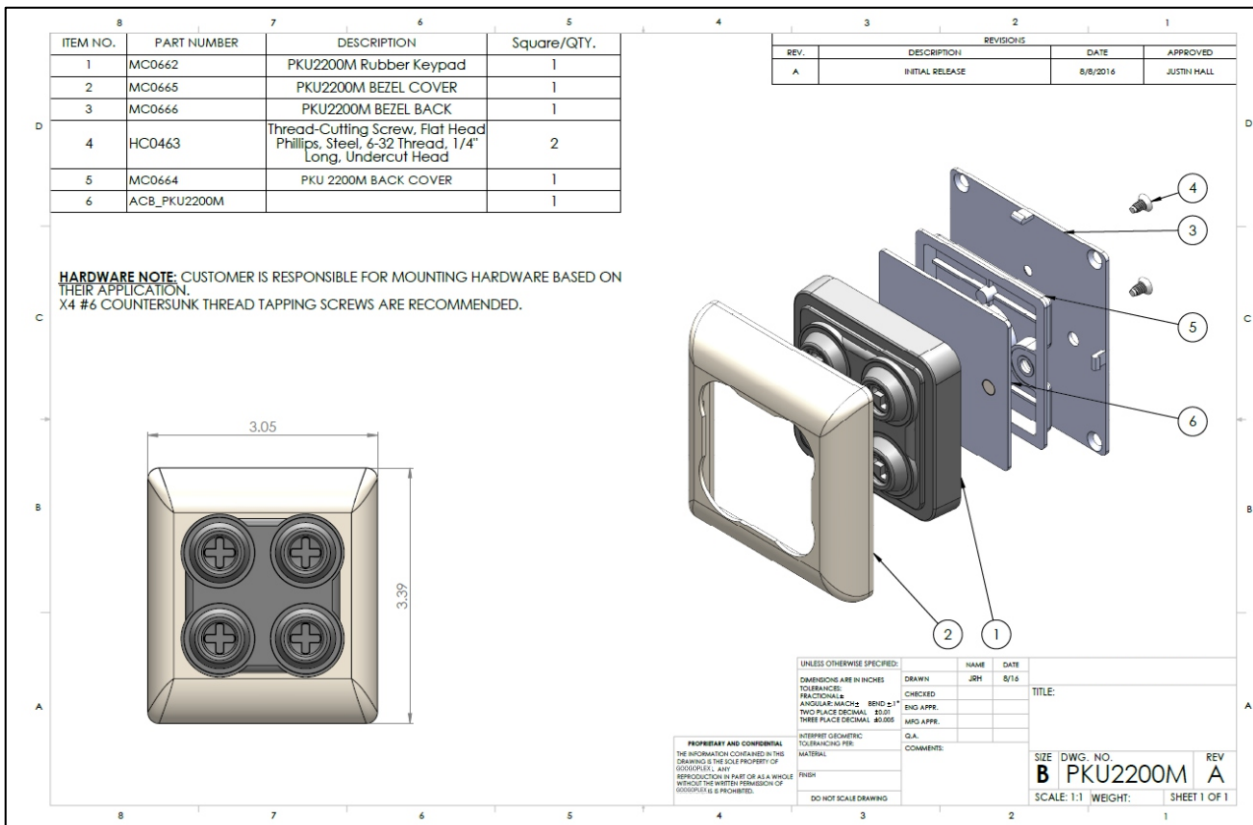

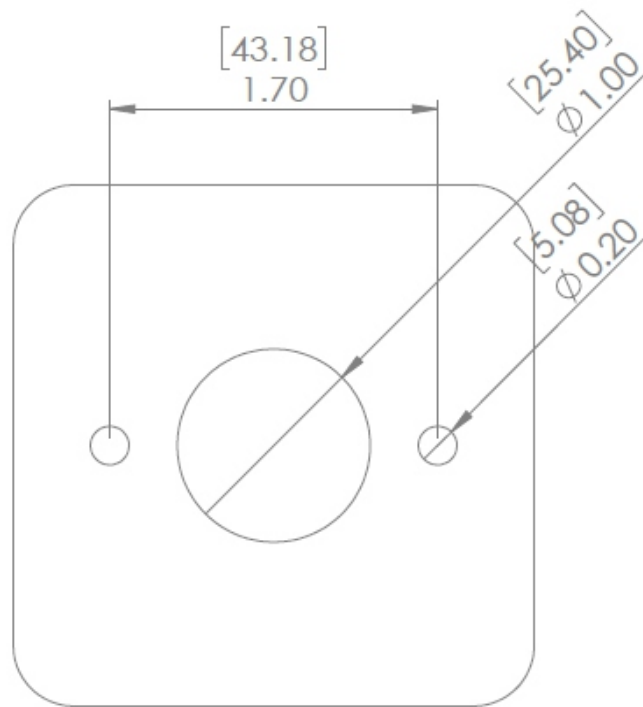

MOUNT ON A FLAT SURFACE ONLY

Part Number: GEC-PKU2200M

Nut Size*: 10-32 UNF S/S

Washer Sizes: M5 Spring Washer S/S, M5 Flat Washer S/S

Torque Maximum: 7 +/- 1 in. lbs

*** DO NOT USE NYLOC NUTS**

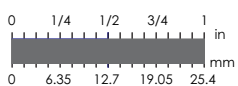

Increments are 1/16"
Scale 1:1

PLEASE VERIFY SCALING PRIOR TO DRILLING

Mounting Template Scale 1:1 (Units in inches (mm))

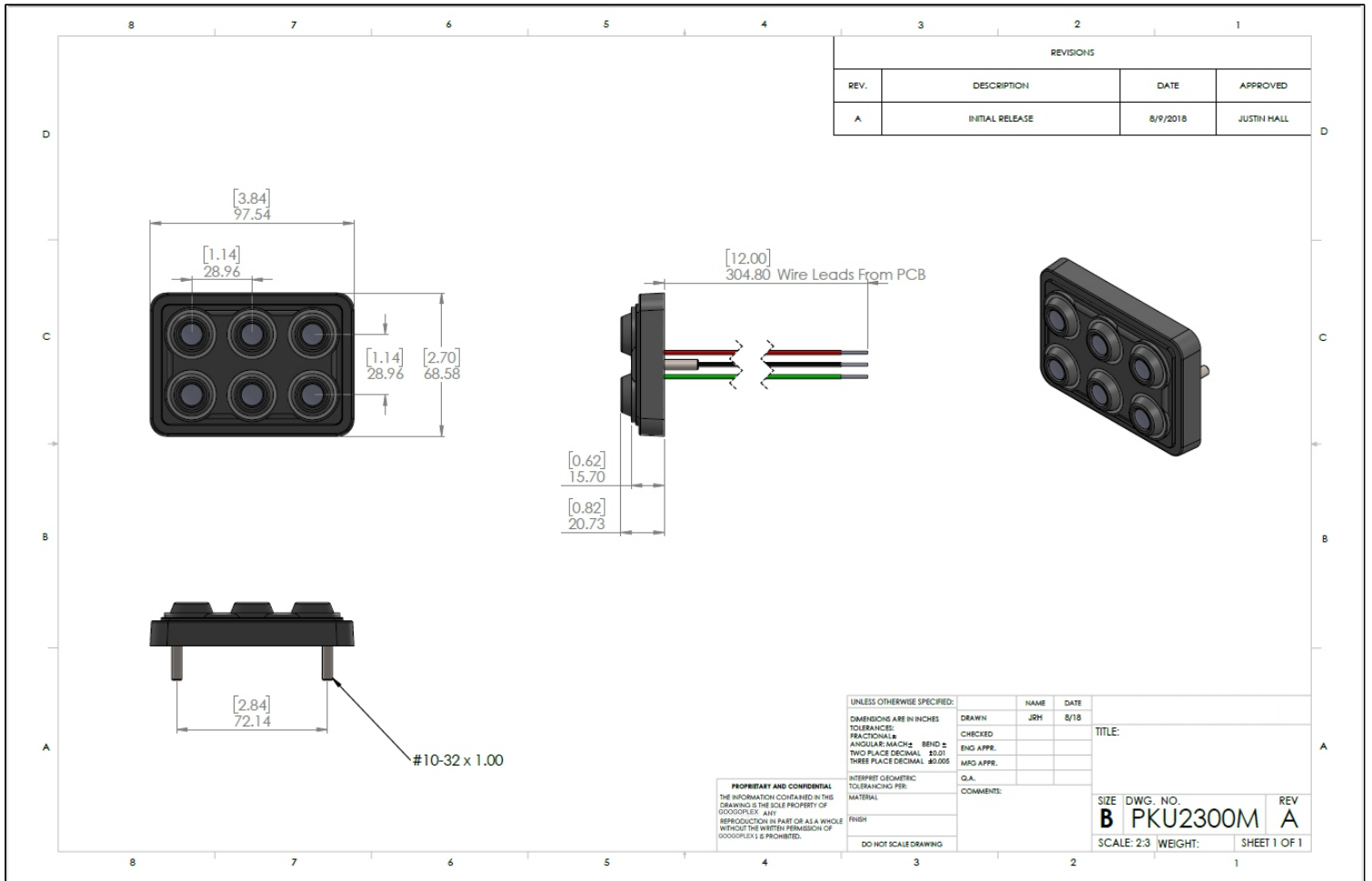

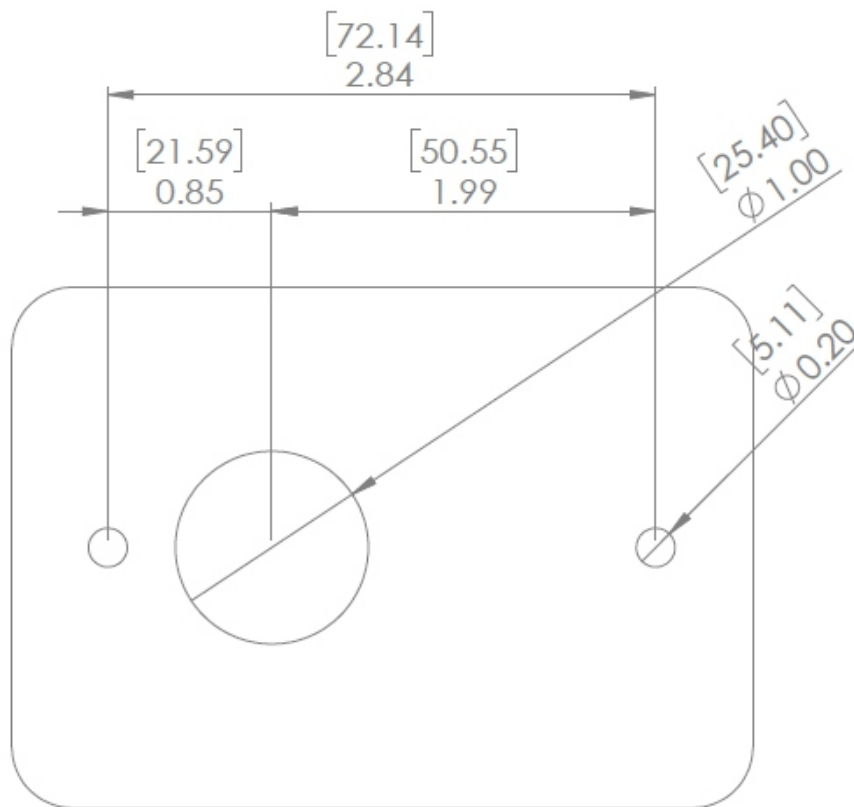

MOUNT ON A FLAT SURFACE ONLY

Part Number: GEC-PKU2300M

Nut Size*: 10-32 UNF S/S

Washer Sizes: M5 Spring Washer S/S, M5 Flat Washer S/S

Torque Maximum: 7 +/- 1 in. lbs

*** DO NOT USE NYLOC NUTS**

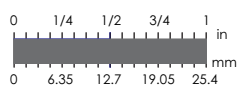

Increments are 1/16"
Scale 1:1

PLEASE VERIFY SCALING PRIOR TO DRILLING

Mounting Template Scale 1:1 (Units in inches (mm))

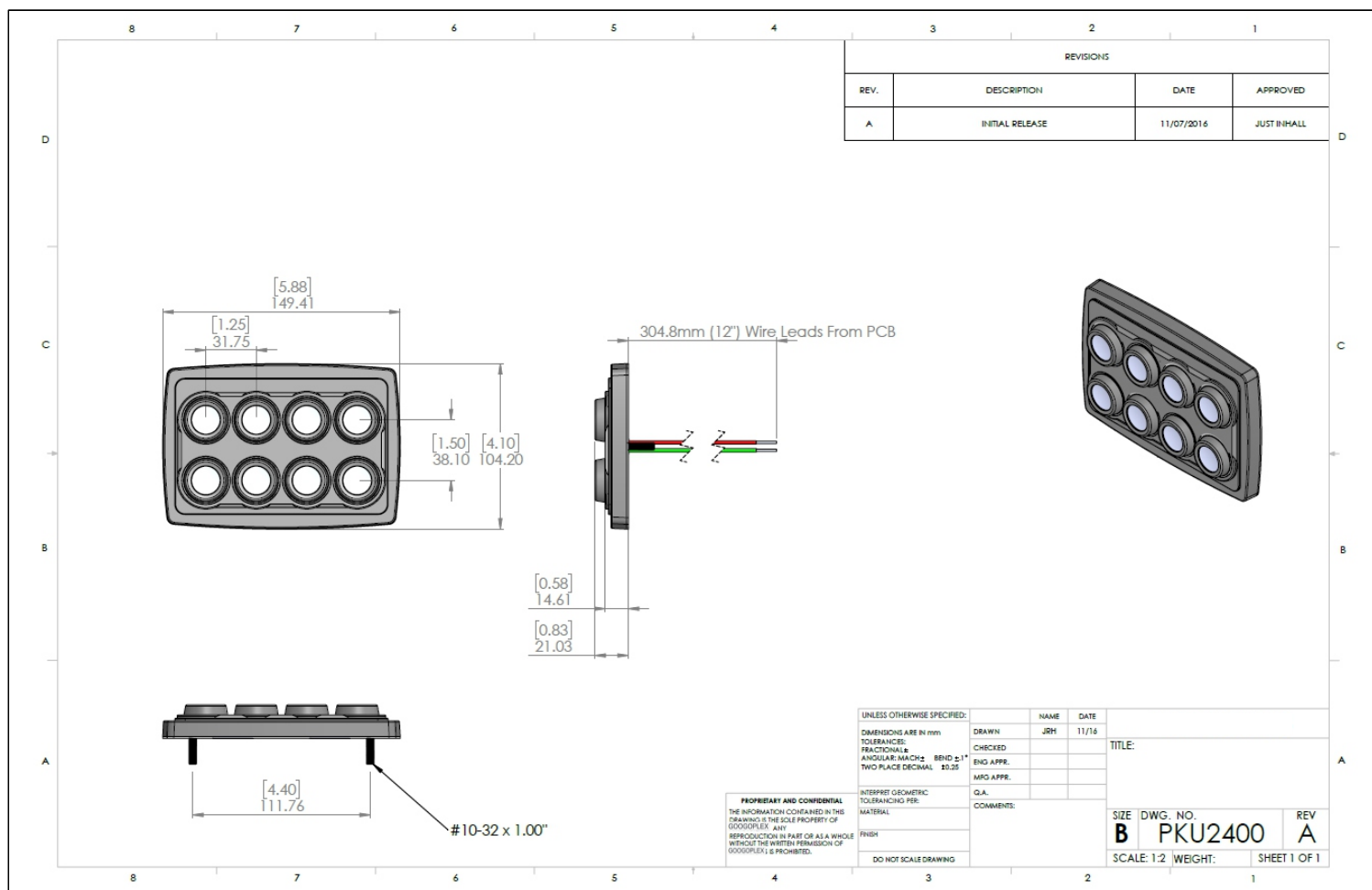

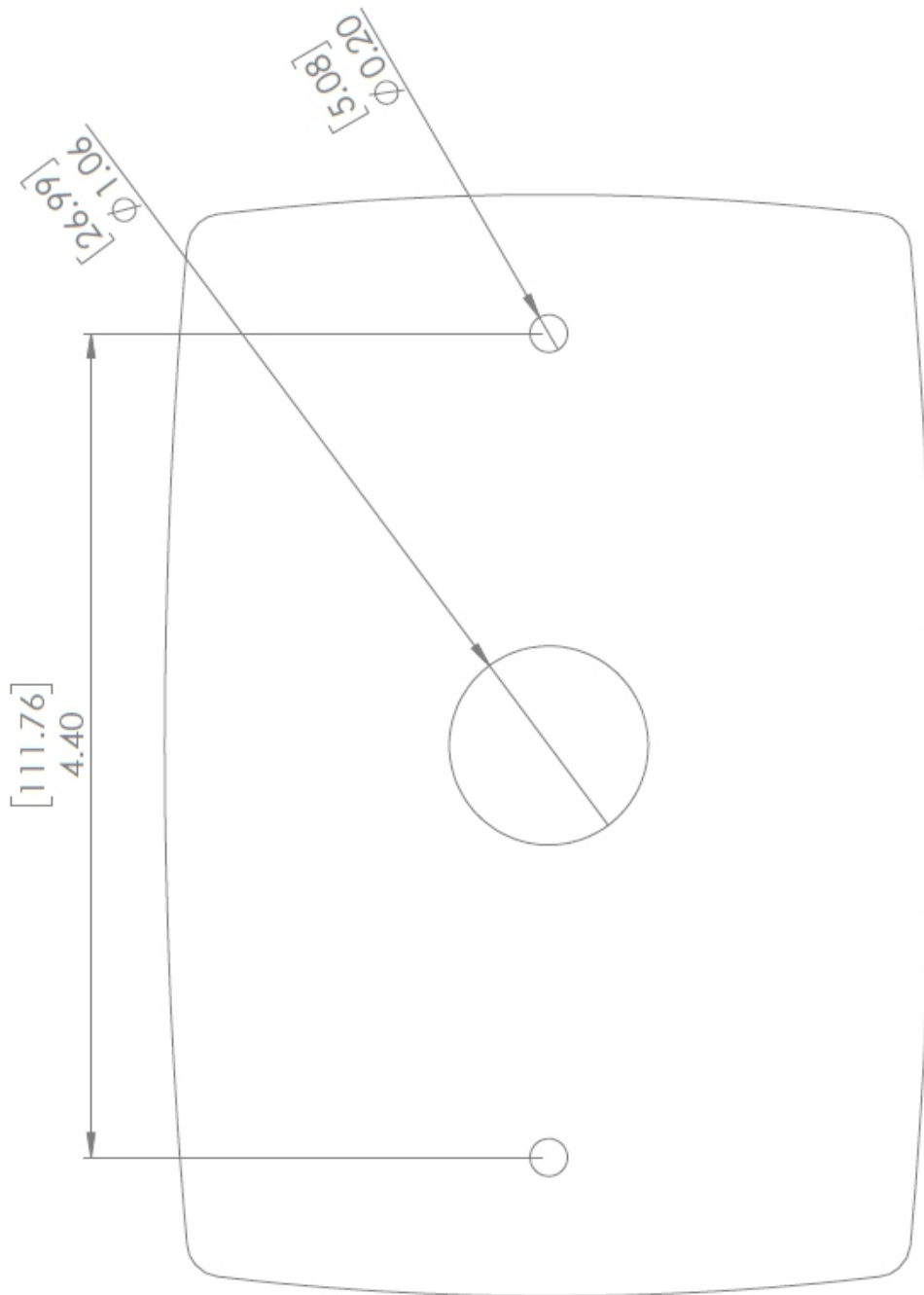

MOUNT ON A FLAT SURFACE ONLY

- Part Number: GEC-PKU2400
- Nut Size*: 10-32 UNF S/S
- Washer Sizes: M5 Spring Washer S/S, M5 Flat Washer S/S
- Torque Maximum: 7 +/- 1 in. lbs
- * DO NOT USE NYLOC NUTS**

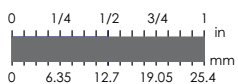

Increments are 1/16"
Scale 1:1

PLEASE VERIFY SCALING PRIOR TO DRILLING
Mounting Template Scale 1:1 (Units in inches (mm))

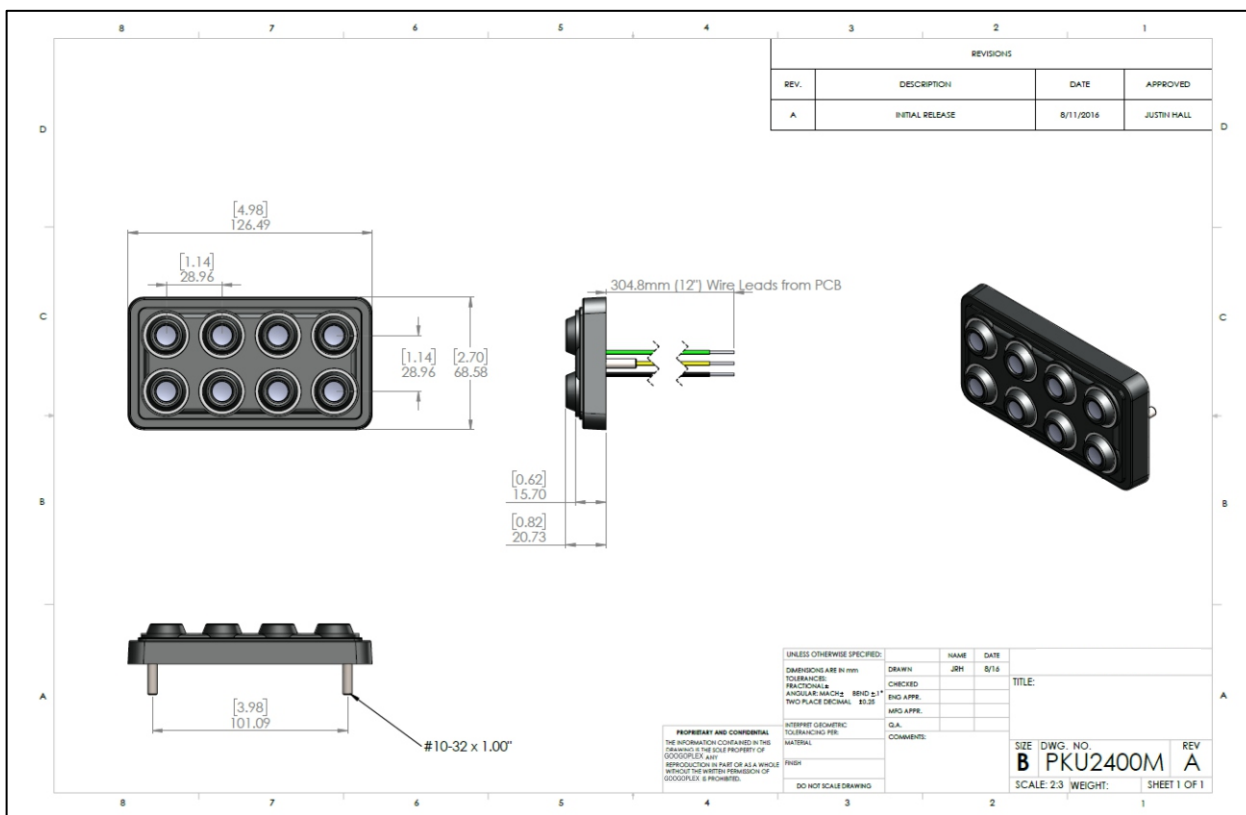

With Finger guard option (P/N: MC0686):

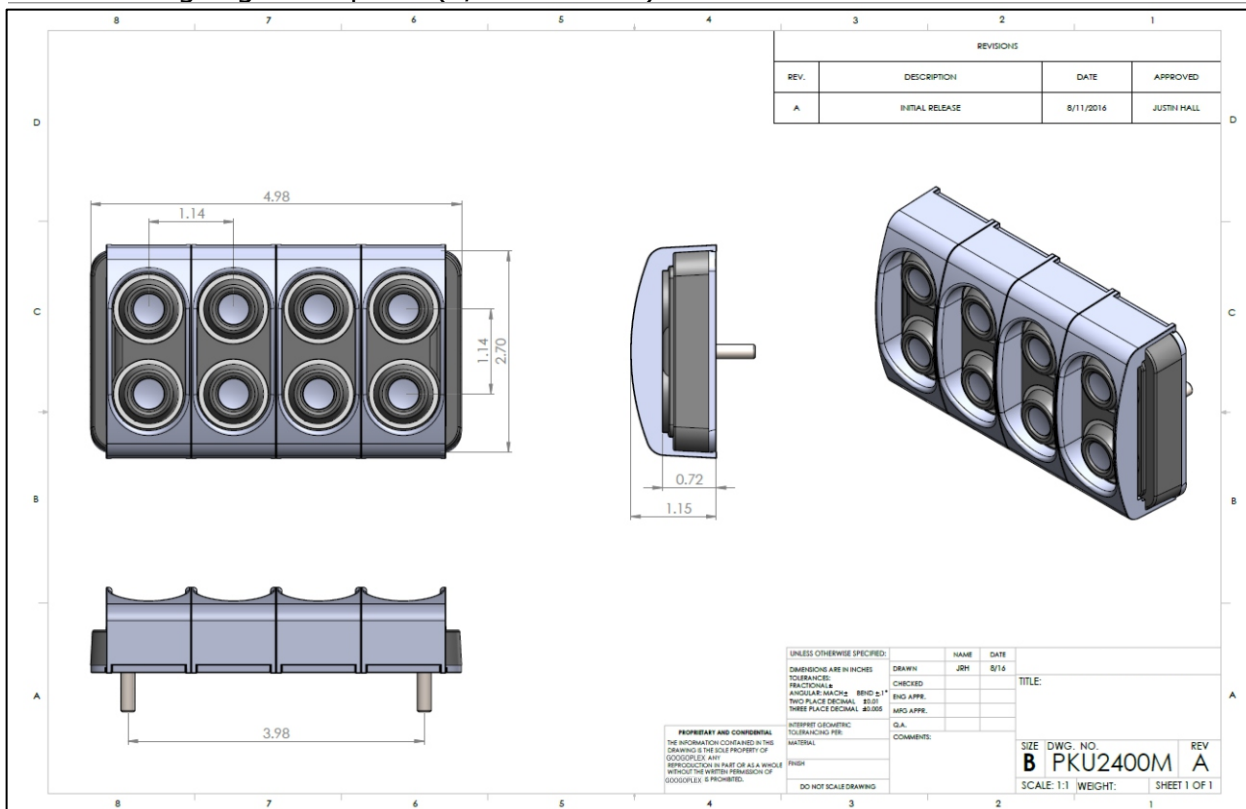

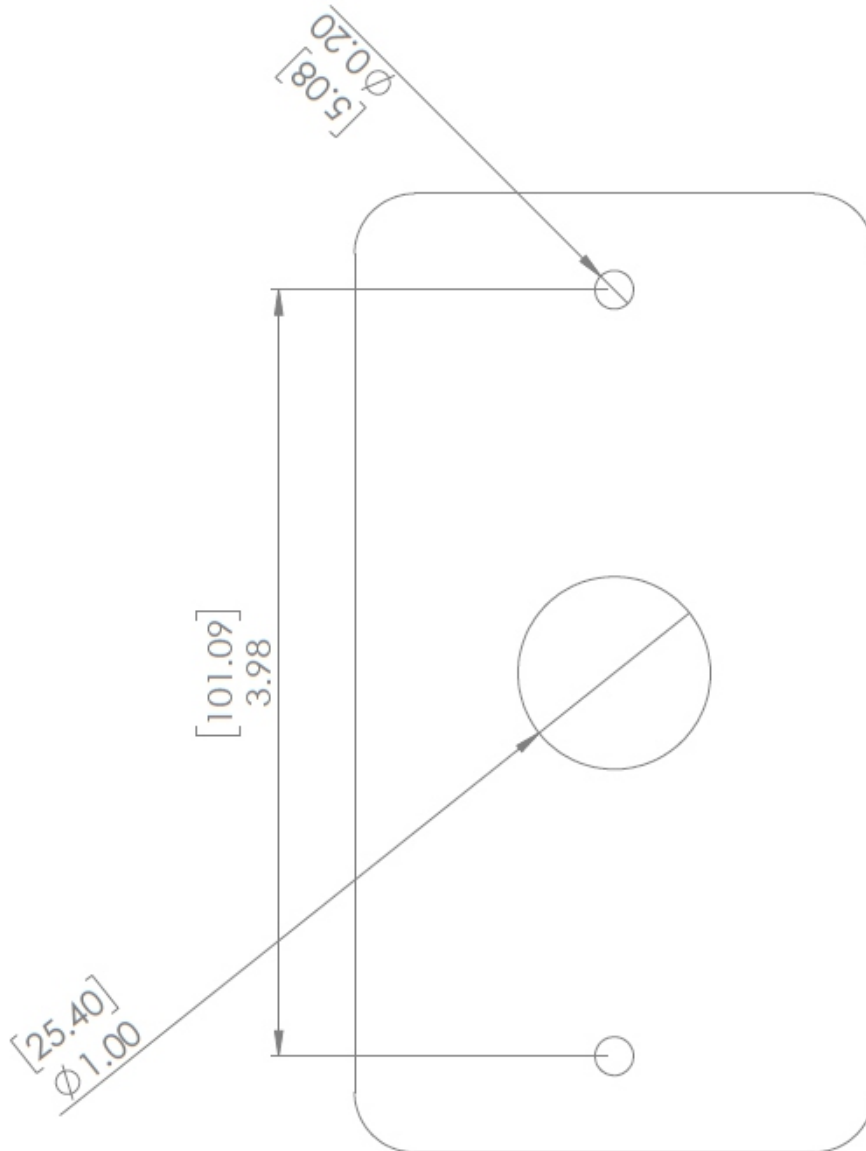

MOUNT ON A FLAT SURFACE ONLY

Part Number: GEC-PKU2400M

Nut Size*: 10-32 UNF S/S

Washer Sizes: M5 Spring Washer S/S, M5 Flat Washer S/S

Torque Maximum: 7 +/- 1 in. lbs

*** DO NOT USE NYLOC NUTS**

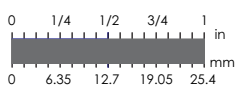

Increments are 1/16"
Scale 1:1

PLEASE VERIFY SCALING PRIOR TO DRILLING

Mounting Template Scale 1:1 (Units in inches (mm))

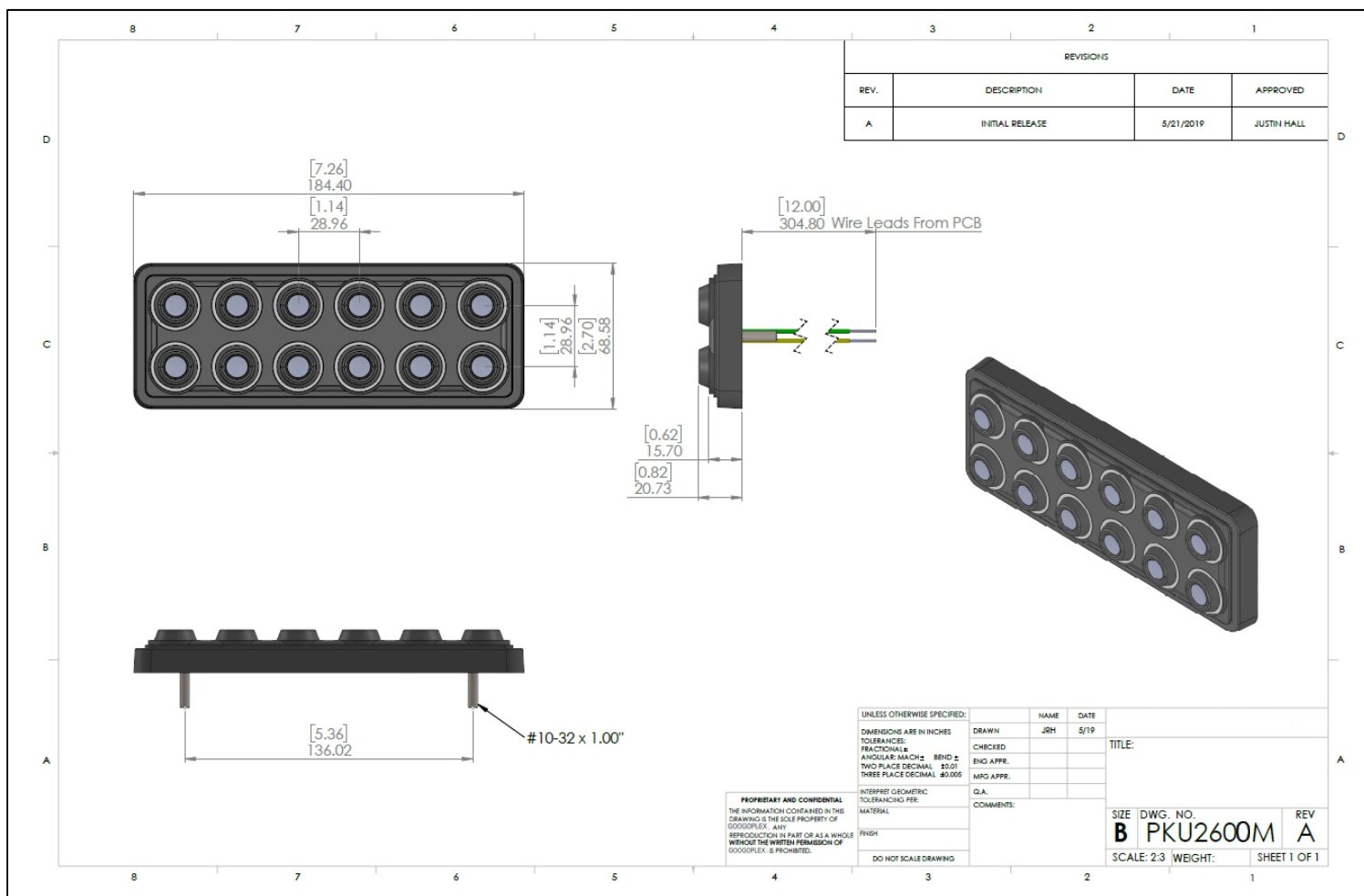

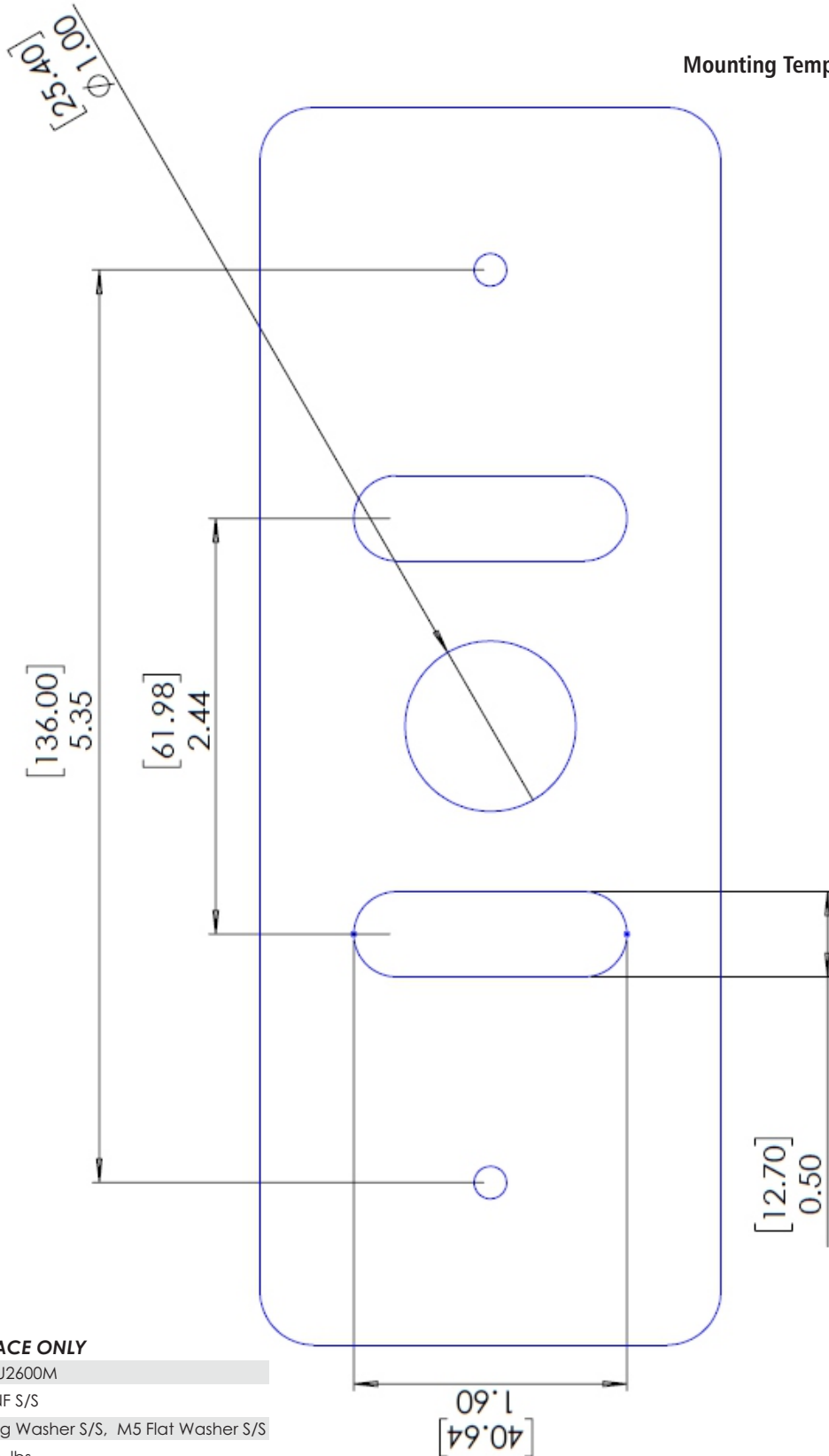

MOUNT ON A FLAT SURFACE ONLY

- Part Number: GEC-PKU2600M
- Nut Size*: 10-32 UNF S/S
- Washer Sizes: M5 Spring Washer S/S, M5 Flat Washer S/S
- Torque Maximum: 7 +/- 1 in. lbs
- * DO NOT USE NYLOC NUTS**

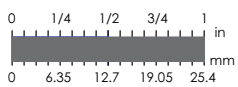

Increments are 1/16"
Scale 1:1

PLEASE VERIFY SCALING PRIOR TO DRILLING
Mounting Template Scale 1:1 (Units in inches (mm))

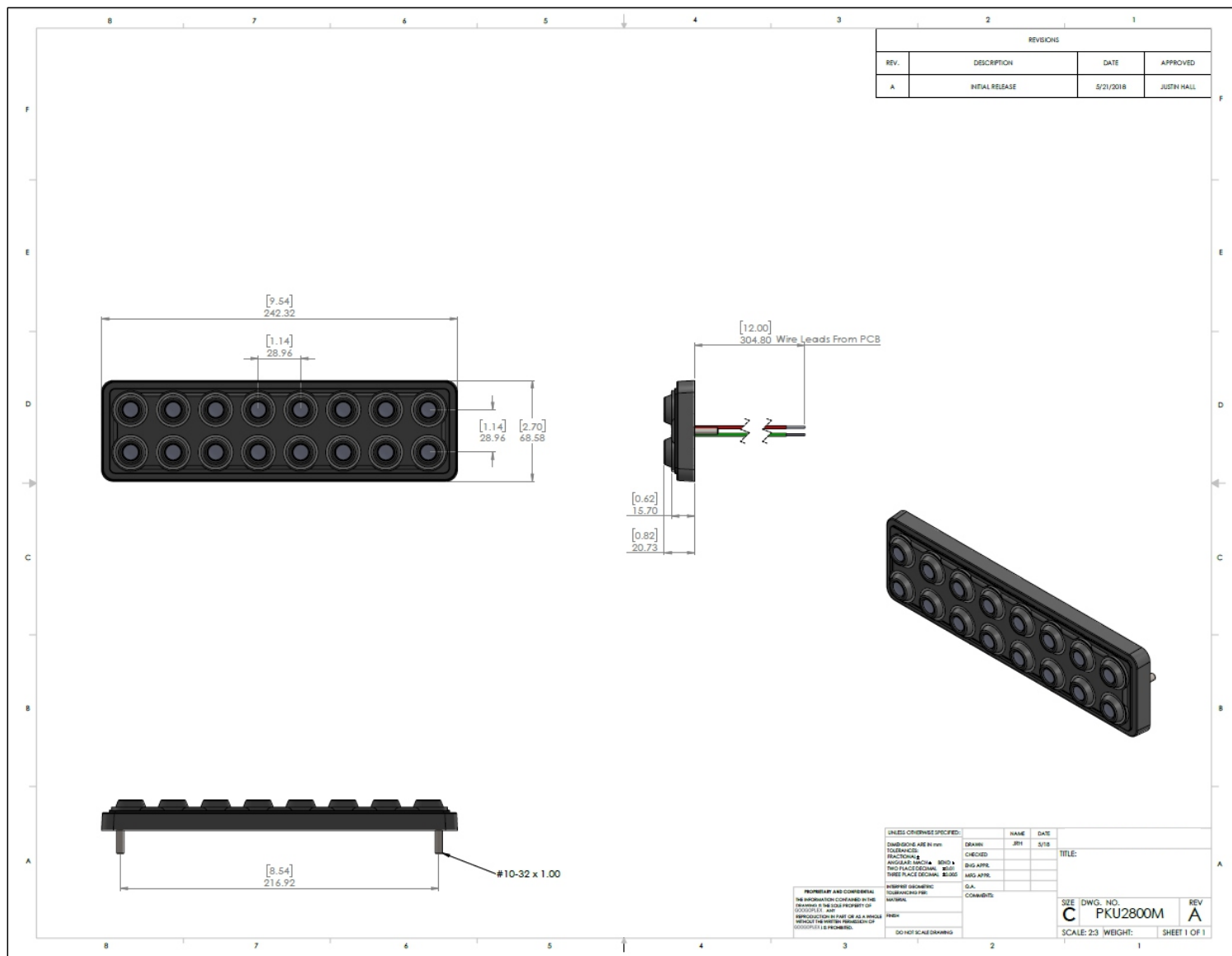



Mounting Template

PKU2800M

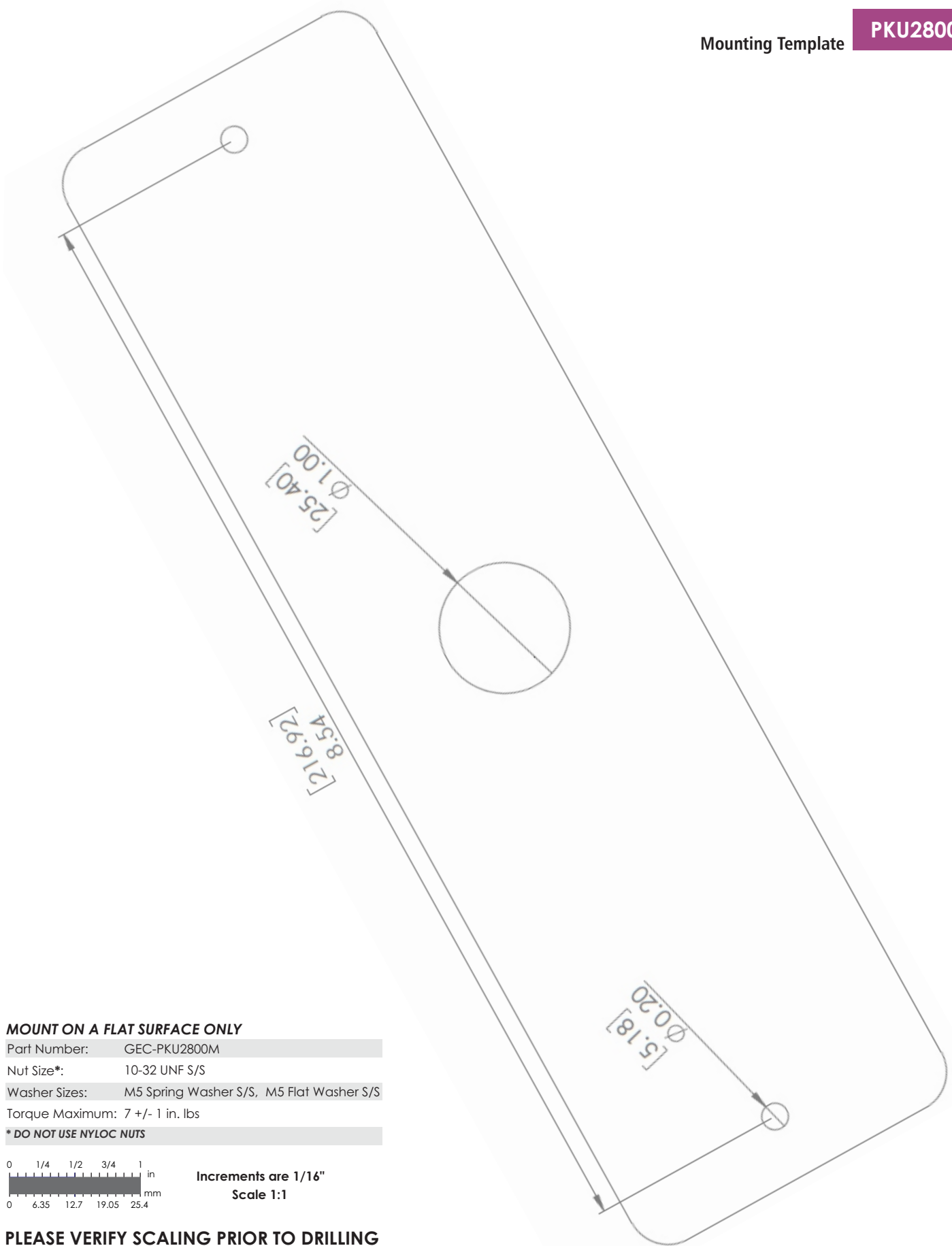

MOUNT ON A FLAT SURFACE ONLY

- Part Number: GEC-PKU2800M
- Nut Size*: 10-32 UNF S/S
- Washer Sizes: M5 Spring Washer S/S, M5 Flat Washer S/S
- Torque Maximum: 7 +/- 1 in. lbs
- * DO NOT USE NYLOC NUTS**

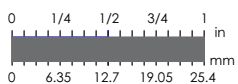

Increments are 1/16"
Scale 1:1

PLEASE VERIFY SCALING PRIOR TO DRILLING
Mounting Template Scale 1:1 (Units in inches (mm))

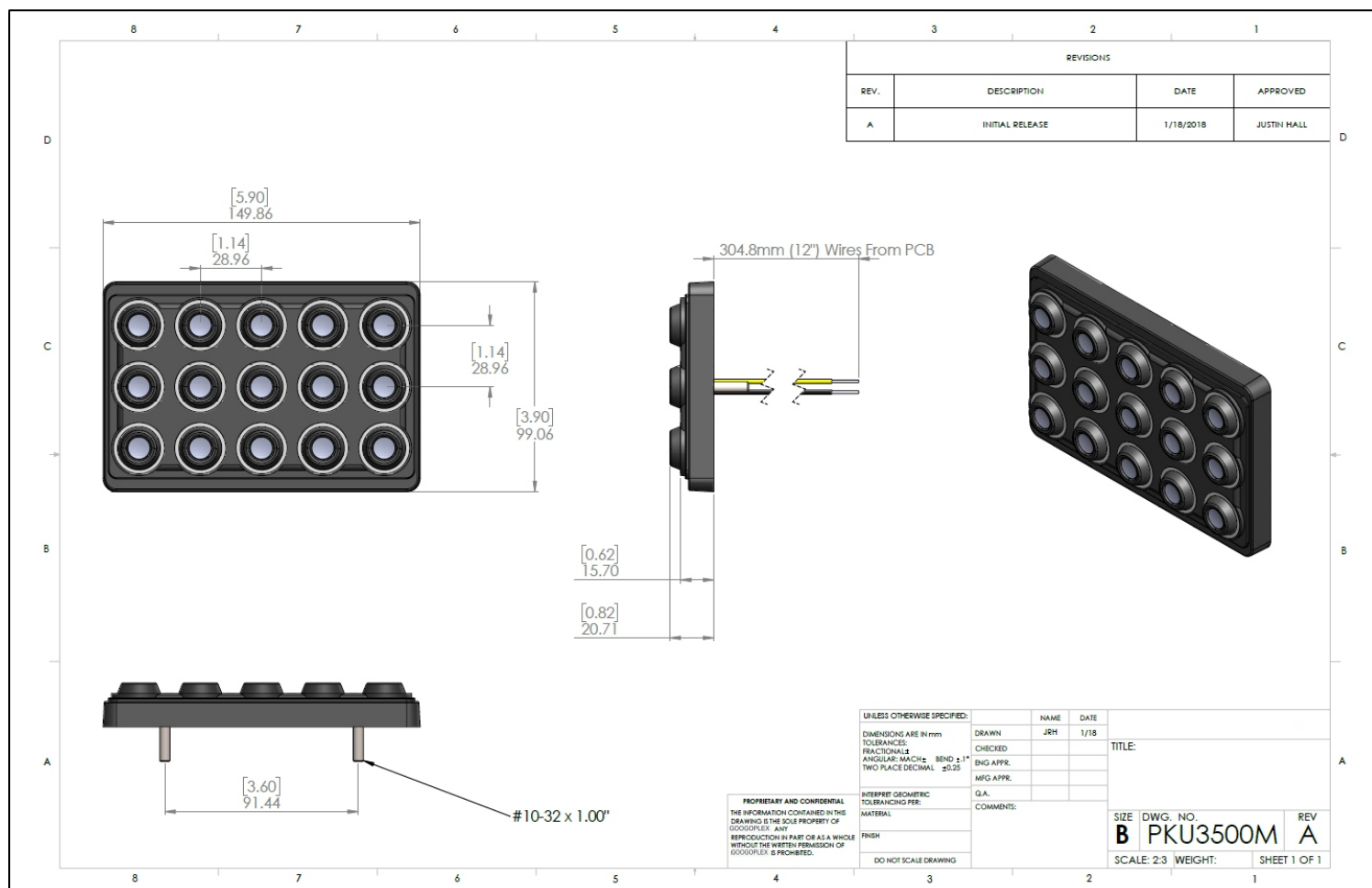



Mounting Template

PKU3500M

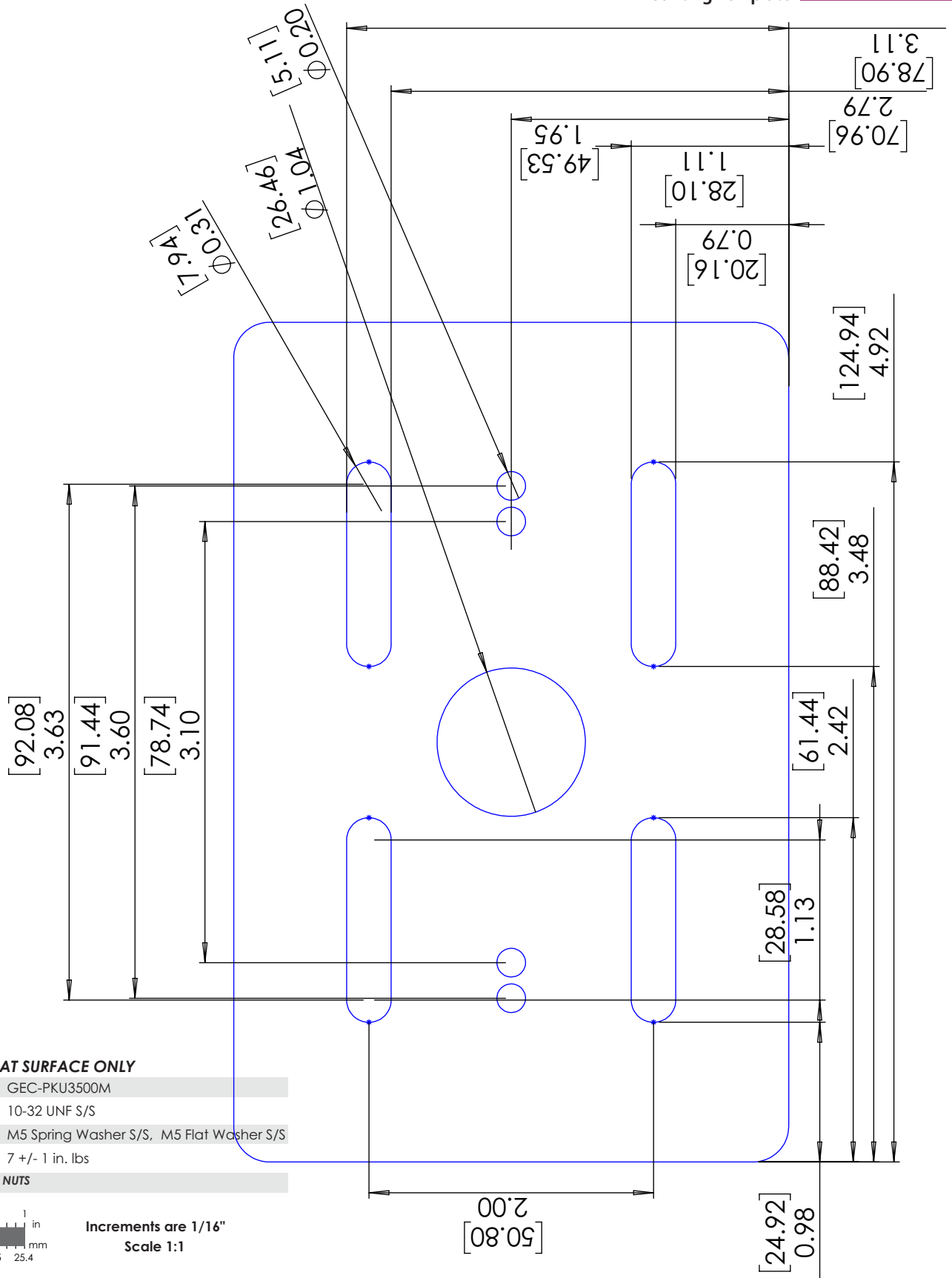

MOUNT ON A FLAT SURFACE ONLY

Part Number: GEC-PKU3500M

Nut Size*: 10-32 UNF S/S

Washer Sizes: M5 Spring Washer S/S, M5 Flat Washer S/S

Torque Maximum: 7 +/- 1 in. lbs

*** DO NOT USE NYLOC NUTS**

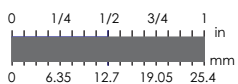

Increments are 1/16"
Scale 1:1

PLEASE VERIFY SCALING PRIOR TO DRILLING

Mounting Template Scale 1:1 (Units in inches (mm))



Revision Date:	Author:	List of Changes or Additions:
09/12/19	Andrew Clayton	Initial Release
02/12/21	Jay Mayo	Updated Torque Specs For All Keypads

This documentation is provided for informational purposes only and is subject to change without notice. No part of this documentation may be reproduced, distributed, or transmitted in any form or by any means, including electronic, mechanical, photocopying, recording or otherwise, or for any purpose without written consent from Googolplex Electric Co.