

RPS



E6441



REVERSE POLARITY SENSOR

OVERVIEW

The Reverse Polarity Sensor is a safety device aimed to protect sensitive electronic devices that could possibly be affected by reversed polarity.

We all know that safety is paramount and we strive to adopt new practices to reduce the chance of electrocution and increase safety, thus making the Reverse Polarity Sensor fundamental for all vehicle, RV and marine vessel owners.

This innovative device works by sensing the polarity of the power input and, if correct, will then energise the relay permitting power to flow through the vehicle switchboard in certain circumstances it will automatically trip the safety switch at the supply point of the power source.

This compact device requires minimum space and is recommended to be installed along with the supplied relay at the vehicle or vessels' switchboard location.

FEATURES

- Max Switching of 500mA @ 240VAC
- Standard: AS/NZ 3100:2009 Incl A1-4
- Certificate: SAA172810

EASY INSTALLATION
MAINTENANCE FREE
SUPER RELIABLE

This device must be installed by a suitably licenced electrician to meet standards of AS/NZS 3100:2009 Incl A1-4. If used outside Australia or New Zealand, please consult local authorities. Manufactured and complies with AS/NZS 3100:2009 Incl A1-4. Certificate No. SAA172810
Maximum switching of 500mA @ 240V ac.

WHEN SAFETY MATTERS

www.googolplex.com.au

KIT INCLUDES :

Polarity Sensor	1	Wiring Diagram	1	Red LED Indicator Lamp	1
240VAC Relay	1	Notice Label	1	Green LED Indicator Lamp	1

DIMENSIONS :

SENSOR

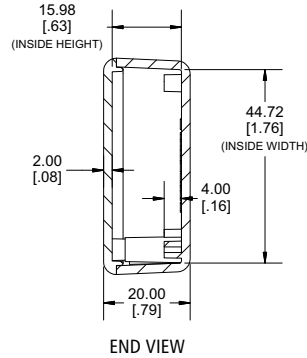
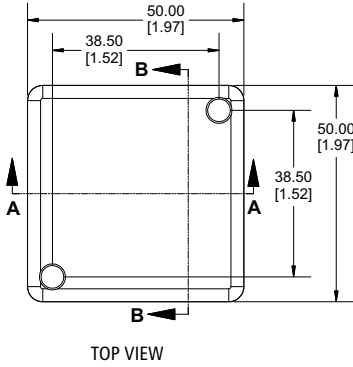

RELAY

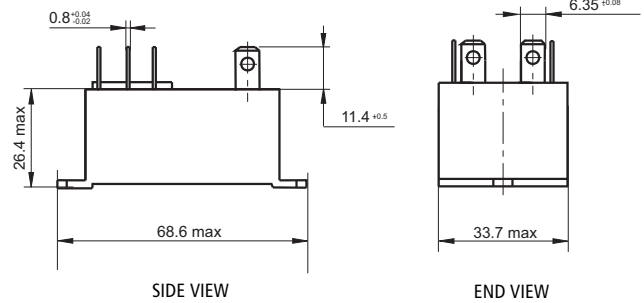

WIRING DIAGRAM :

THE REVERSE POLARITY SENSOR MUST BE INSTALLED BY A LICENSED ELECTRICIAN.

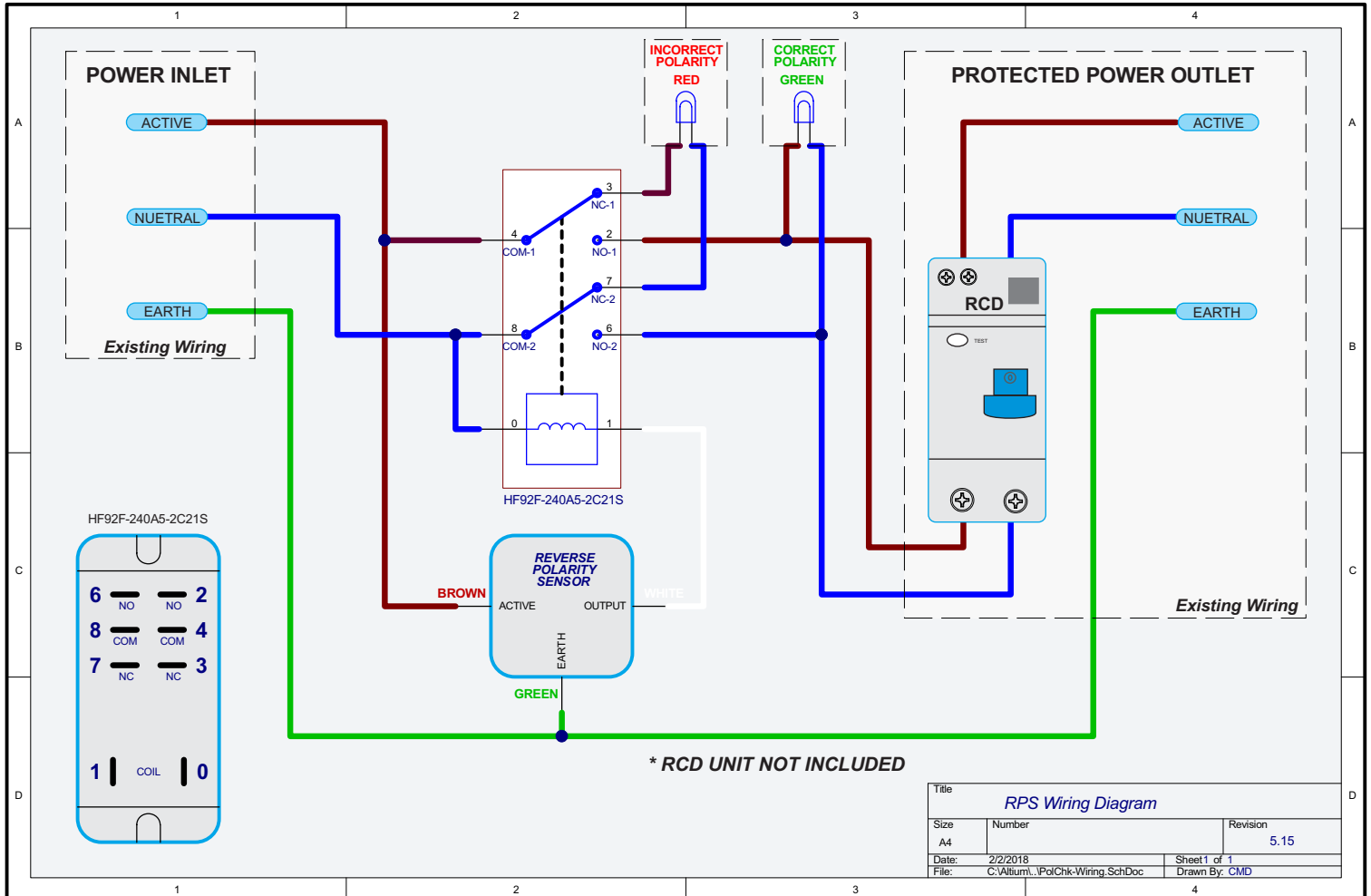

WARNING :

This device must be installed by a suitably licenced electrician to meet standards of AS/NZS 3100:2009 Incl A1-4. If used outside Australia or New Zealand, please consult local authorities. Manufactured and complies with AS/NZS 3100:2009 Incl A1-4. Certificate No. SAA172810
Maximum switching of 500mA @ 240V ac.

The Polarity Sensor can be applied under the AS3004.2:2008 S5.5.3.2 a.c. (Protection against reverse polarity in the supply lead) and can also be used for NSCV Part C Section 5 Subsection 5B (Electrical) Paragraph 4.7.1.c (Shore Supply)
Please see wiring diagram for specific connectivity.

