

PBA



E6441



Australian
Made



PARK BRAKE ALARM

OVERVIEW

The Park Brake Alarm is a safety device intended as an audible warning system to alert both the driver and any personal in the general area when the Park Brake has not been applied.

This simple but intelligent device constantly observes both the Door Switch and Park Brake Switch signals. If the Cabin Door is OPENED and the Park Brake has NOT been APPLIED, the device will instantaneously sound both the module Alarm and the vehicle Horn.

The vehicle Horn will continue to sound even when the Cabin Door has been closed (applying the Park Brake will immediately DISABLE both Alarm and Horn notifications).

The Park Brake Alarm device also has an optional connection, where the module Alarm will sound for 2 seconds BEFORE the vehicle Horn is sounded. This function sounds as a warning to the driver as a reminder to APPLY the Park Brake.

The compact, sealed and maintenance free device has the added benefit of being multi-voltage (12-24 VDC).

With hassle free installation the Park Brake Alarm is an excellent economical safety device.

FEATURES

- Multi-voltage (12-24 VDC)
- Australian Made & Designed
- Fully Encapsulated Enclosure

EASY INSTALLATION
MAINTENANCE FREE
SUPER RELIABLE

WHEN SAFETY MATTERS

www.googolplex.com.au

DIMENSIONS :

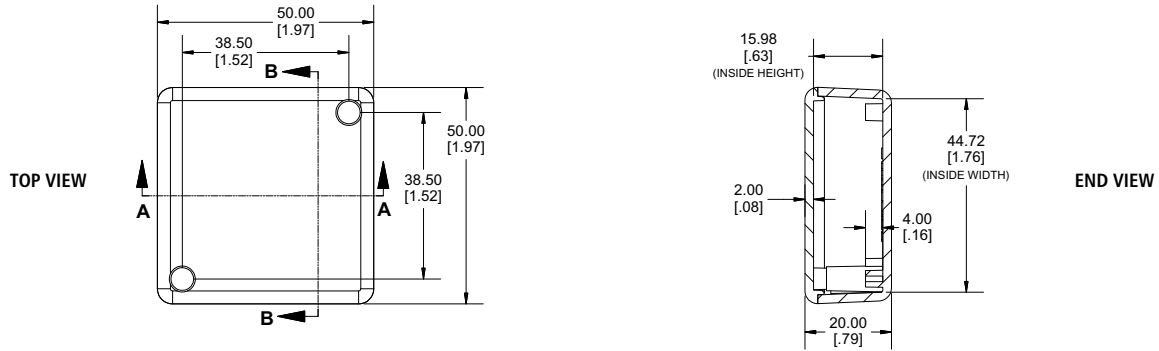

INSTALLATION & WIRING :

The installer needs to connect the Door Switch Signal and Park Brake Signal onto the Park Brake Alarm in order for the Park Brake Alarm to function correctly.

Separate Inputs are provided for High Active and Low Active Input, the end user needs only to select and connect one of them.

RED	B+	BATTERY POSITIVE	+9 TO 32V
BLACK	B-	BATTERY NEGATIVE	
GREEN	PRK.BR.L	PARK BRAKE SWITCH INPUT	ACTIVE LOW
ORANGE	PRK.BR.H	PARK BRAKE SWITCH INPUT	ACTIVE HIGH
BROWN	DR.SW.L	DOOR SWITCH INPUT	ACTIVE LOW
DARK BLUE	DR.SW.H	DOOR SWITCH INPUT	ACTIVE HIGH
YELLOW	EX.BUZZER.1	EXTERNAL OUTPUT 2 (Output to Energise Horn Relay) 2 Sec Delay	SWITCH to GROUND
WHITE	EX.BUZZER.2	EXTERNAL OUTPUT 2 (Output to Energise Horn Relay) NO Delay	SWITCH to GROUND

TYPICAL CONNECTION :

* For installation purposes please download the wiring diagram

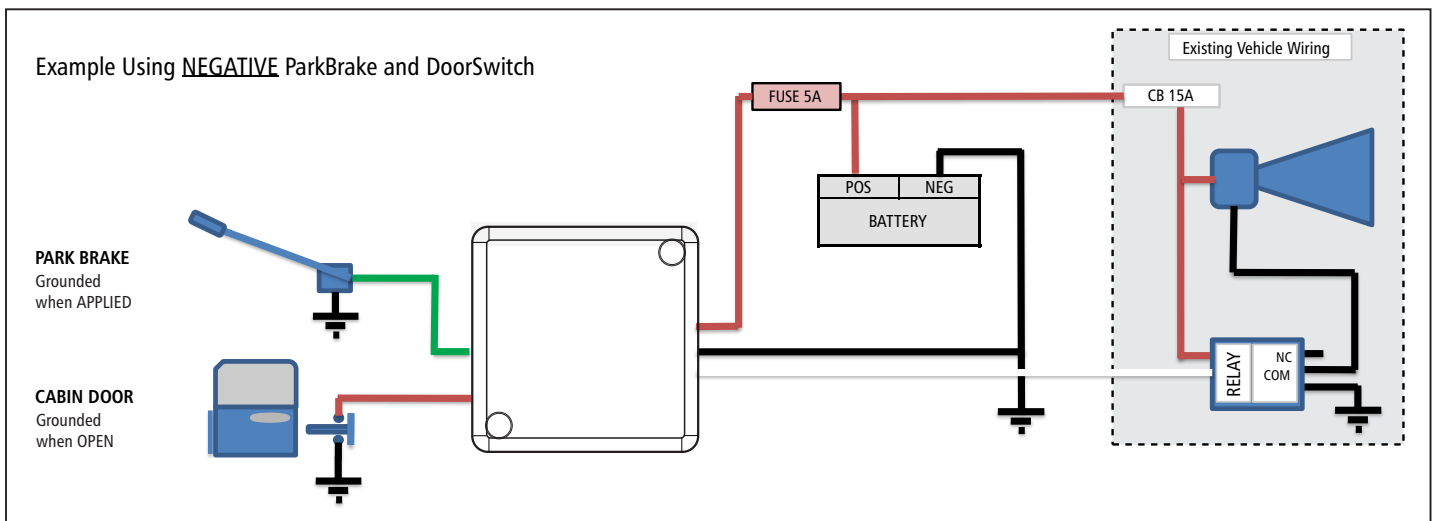

PBA WIRING (2)

Googolplex Electric Co. (GEC) reserves the right to make changes or discontinue any product or service identified in this publication without notice. GEC advises its customers to obtain the latest information to verify, before placing any orders, that the information being relied upon is current. GEC assumes no responsibility for infringement of patents or rights of others based on GEC applications, assistance or product specifications since GEC does not possess full access concerning the use or the application of customers products. GEC also assumes no responsibility for customers product designs.