



CANopen

J1939

PM15 GEN3



OVERVIEW

The POWERMATE 15 GENERATION 3 (PM15G3) load handler is the latest addition to our digital switching system family.

An innovative Australian designed and manufactured control solution for all your electronic needs. Rugged, flexible, reliable and specifically designed for a multitude of applications which allows customisation for distinct digital controlling and monitoring.

If optimal safety, cost reduction and improved adaptability is imperative to you then the PM15G3 is more than ready to undertake your next technical project.

POWERMATE LOAD CONTROLLER

This product has been successfully launched in the Australian market for trucking fleets, mining vehicles, the marine industry, Antarctic research vehicles, and government service vehicles amongst others.

Some of our existing users include: Isuzu; Volvo; Dyno Nobel, Ergon; Telstra; Caterpillar; Brisbane City Council; Queensland Fire service; Australian Government and Origin Energy.

Increases Safety: Pro-actively diagnoses and prevents accidents and injury.

Reduces Costs: Avoids breakdown and vehicle downtime and prolonging the life of the vehicle.

Enhances Customisability: Allowing for solutions to be tailored for individual requirements.

SPECIAL FEATURES

- 12/24V Power Supply
- Over-current Protection on All Outputs
- Over-Voltage ESD Protection
- RS-485/J1939/CAN Communication
- Supports OmniBus Protocol

INTELLIGENT POWER

www.googolplex.com.au

Page 1: GEC-PM15G3_SpecSheet_Ver.1

PURPOSE

The purpose of this document is to describe the PowerMate 15 Gen3 which has been designed for the Automotive, Marine, Mining and RV industries.

INCLUSIONS

The standard system will be shipped with the following items:

Description	Quantity
POWERMATE 15 G3 Module	1
Connection Kit	1
Pinout Sheet	1

PURPOSE

The PowerMate 15 Gen3 (PM15 G3) receives switch commands from the keypads, interfaces or CANbus and then processes these commands based on the current system status. The response to a switch command may be an activation or deactivation of a circuit, the start of a timed function or in systems with keyless ignition the locking or unlocking of the system.

The PM15 G3 then sends the system status information to turn on/off the indicator LED's and backlights. The PM15 G3 incorporates solid state technology which uses MOSFET's for switching and over-current protection.

ELECTRICAL FEATURES

- 12/24V Power Supply
- 120 Ampere Total Input Current
- 16 MOSFETs Output Rated 20A Each (Switched to Battery ONLY)
- 16 Digital Sense Inputs (5-30V DC)
- 4 Resistive Analog Inputs (300-5K ohms)
- 2 Voltage Analog Inputs (0-30V DC)
- Over-current Protection on All Outputs (Software Settable)
- Soft Start for handling high inrush devices like inductive or capacitive loading
- Programmable Functions (EG. Toggle, Momentary, Timed, PWM, etc.)
- Keypad Control and Indication of Output Circuit operation and faults
- Over-Voltage ESD Protection
- Supports CAN Protocols J1939, CANOpen, CANstd up to 500kbps
- Supports Battery Voltages from minimum 10 volts to maximum 30 volts

FUNCTIONAL FEATURES

- Significantly less wiring and connections (up to 60%), avoiding cluttered vehicle wiring
- Programmable Software generated controls, thereby easily tailoring to future needs
- Real-time Monitoring, logging, diagnostic testing through a Connectivity Kit to a laptop and utilizing Keypad LED's
- CANbus Enabled
- Simple Installation by Auto Electrician
- Manages Output Over-Currents to avoid wiring and load damage
- Designed and tested for use in multiple temperature environments
- Built-in Reverse Polarity Connection Protection
- Compact and Light Weight

HUMAN ERROR SCENARIOS - RESOLVED THROUGH THE POWERMATE 15 Gen3

- Driver exits a Vehicle without applying the Park Brake
- Driver drives away with Toolbox Door open
- Driver drives away without Tipper Body being fully down
- Operator fails to stow Tailgate Lifter in the Stowed position
- Operator fails to maintain Engine Oil and Coolant Levels
- Driver drives away without Crane Home or Legs Stowed
- Driver inadvertently leaves Beacons or Lighting ON while driving at speed (ADR Compliance)
- Driver inadvertently leaves PTO Engaged while driving at speed
- Driver inadvertently leaves Diff Locks ON while driving at speed

DEVICE OVERVIEW

POWERMATE 15 Gen3 (PM15G3) is a digital switching solution developed for the transportation market. It provides in one package, state of the art digital switching technology and an easy to understand user interface for designers, with an extensive and sophisticated menu of switching solutions.

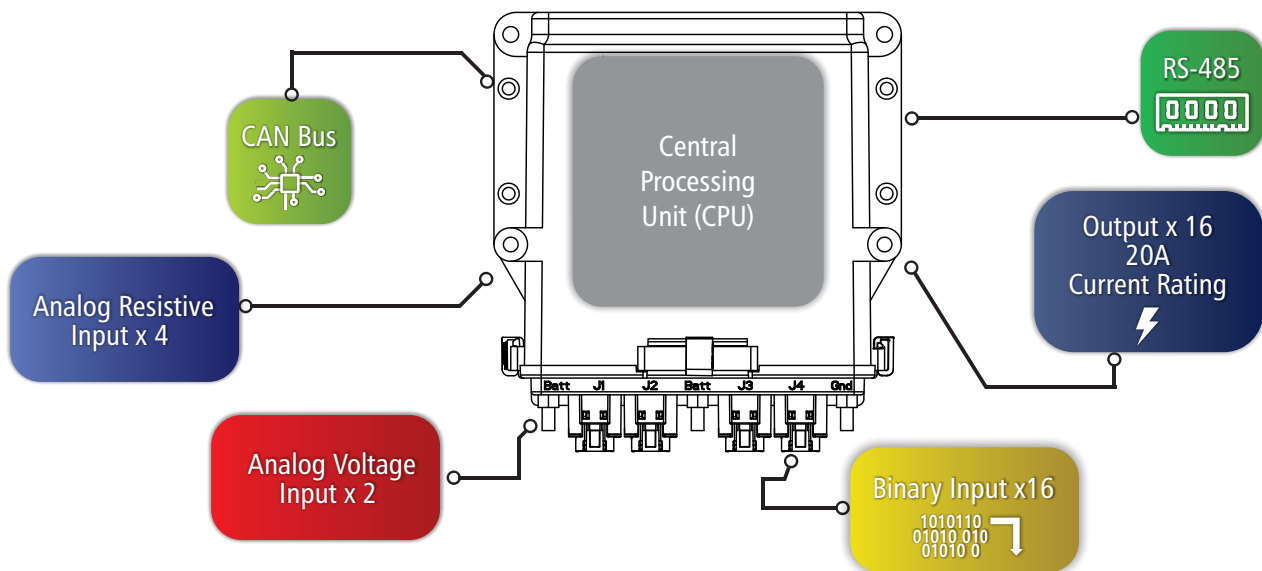

HEADER OVERVIEW

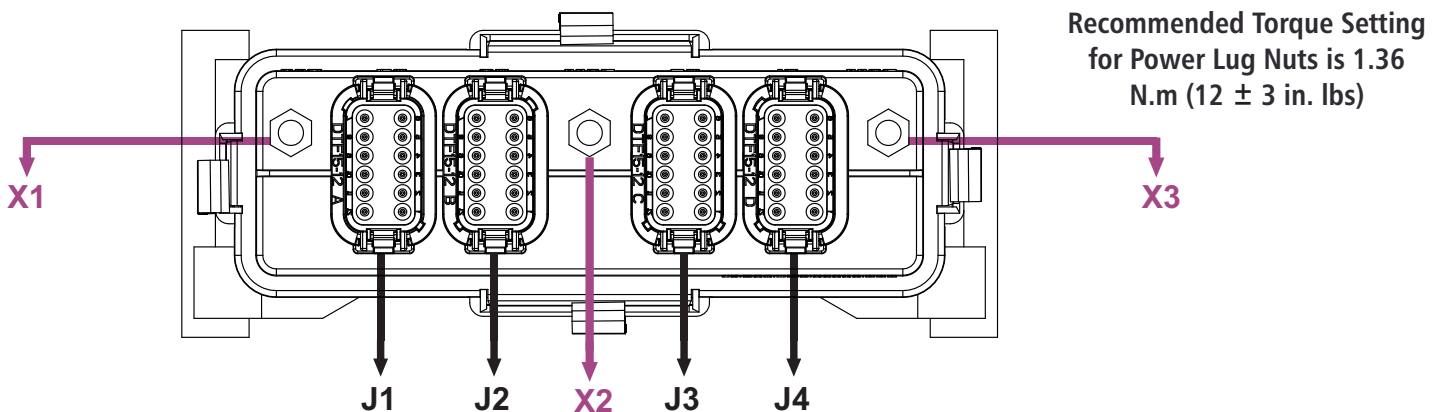

- J1 - Deutsch compatible 12 cavity receptacle (suits supplied DSS-DT06-12SA)
- J2 - Deutsch compatible 12 cavity receptacle (suits supplied DSS-DT06-12SB)
- J3 - Deutsch compatible 12 cavity receptacle (suits supplied DSS-DT06-12SC)
- J4 - Deutsch compatible 12 cavity receptacle (suits supplied DSS-DT06-12SD)

- X1 - 12/24 VDC M6 Power Stud
- X2 - 12/24 VDC M6 Power Stud
- X3 - 0 VDC M6 Ground Stud

PINOUT SHEET

DEUTSCH	OC AMPS	OUTPUT Circuit NAME	
J2-1	20	Output-1	STB
J2-2	20	Output-2	STB
J2-3	20	Output-3	STB
J2-4	20	Output-4	STB
J2-5	20	Output-5	STB
J2-6	20	Output-6	STB
J2-7	20	Output-7	STB
J3-1	20	Output-8	STB
J3-2	20	Output-9	STB
J3-3	20	Output-10	STB
J3-4	20	Output-11	STB
J3-5	20	Output-12	STB
J3-6	20	Output-13	STB
J3-7	20	Output-14	STB
J4-1	20	Output-15	STB
J4-2	20	Output-16	STB
DEUTSCH	Function	BINARY INPUT Circuit NAME	Sense
J1-1	Binput-1	Binput 1	
J1-2	Binput-2	Binput 2	
J1-3	Binput-3	Binput 3	
J1-4	Binput-4	Binput 4	
J1-5	Binput-5	Binput 5	
J1-6	Binput-6	Binput 6	
J1-7	Binput-7	Binput 7	
J1-8	Binput-8	Binput 8	
J2-8	Binput-9	Binput 9	
J2-9	Binput-10	Binput 10	
J2-10	Binput-11	Binput 11	
J2-11	Binput-12	Binput 12	
J2-12	Binput-13	Binput 13	
J3-8	Binput-14	Binput 14	
J4-9	Binput-15	Binput 15	
J4-10	Binput-16	Binput 16	
DEUTSCH	Function	ANALOG INPUT Circuit NAME	Sense
J4-11	Analog-1	Analog 1	300R-5K
J4-12	Analog-2	Analog 2	300R-5K
J3-9	Analog-3	Analog 3	300R-5K
J3-10	Analog-4	Analog 4	300R-5K
J3-11	Analog-5	Analog 5	(<30V)
J3-12	Analog-6	Analog 6	(<30V)
DEUTSCH	Function	COMMS Circuit NAME	Sense
J1-9	OMNI_NEG	Keypad OMNI_NEG	
J1-10	OMNI_POS	Keypad OMNI_POS	
J1-11	CAN_BUS Lo	CANbus LOW	Optional (250K)
J1-12	CAN_BUS Hi	CANbus HIGH	Optional (250K)
STUD	Function	POWER Circuit NAME	
X1	12/24V DC	Power VDDA	
X2	12/24V DC	Power VDDB	
X3	0V DC	Ground	

DETAILED DESCRIPTION

POWER

PowerMate 15 Gen3 has the unique ability to divide power voltages within the device via two (2) connected Power Studs. Each Power Stud manages 8 outputs that can be regulated at either 12V or 24V, i.e.

- Battery Stud #1 @ 12V
- Battery Stud #2 @ 24V

Each Power Stud has an 80 Ampere input current with a total maximum of 120 Ampere across the whole device.

MOSFET OUTPUT

PowerMate 15 Gen3 has 16 MOSFET Outputs which are rated at 20 Ampere each maximum. All outputs can ONLY be Switched to Battery. Each Output is double protected by hardware and software, i.e.

- PowerMate 15 Gen3 can shut down the MOSFET in case of Over-Current and
- In case of software exception, the fuse will be blown to protect the circuit from further damages.

BINARY INPUT

PowerMate 15 Gen3 has 16 Binary Inputs which are capable of reading Digital High/Low Input. Each Binary Input can be configured as Switch to Ground (STG)/Switch to Battery (STB) and High/Low Active independently:

1. STG Active Input examples: - Park Brake, Door Switch, Locker Doors etc.
2. STB Active Input examples: - Ignition, PTO, High Beam etc.

ALL Binary Inputs by default are configured as STB Active Inputs.

OMNIBUS INTERFACE

PowerMate 15 Gen3 has one RS-485 channel. It can communicate with other PowerMate Series Digital Switching modules and Keypads within the system network using the OmniBus Interface.

- PowerMate 15 Gen3 is default configured to communicate at 9600 bps (9600, 8-N-1).
- The user can retrieve system status such as output and input pin conditions, current status, analog input values as well as battery status.

CAN INTERFACE

PowerMate 15 Gen3 has one CAN channel. It can communicate with other PowerMate Series Digital Switching Systems using CAN Interface.

- PowerMate 15 Gen3 is default configured to communicate at 250 kbps.
- PowerMate 15 Gen3 supports CAN protocols such as J1939, CANOpen, CANStandard etc.
- Common Status that the PowerMate Series Digital Switching Systems would be able to obtain from the CANbus include:
 - Vehicle Speed
 - Engine Revolution Per Minute
 - Gear Position

Further customisation is possible to suit specific client requirements.

INSTALLATION OVERVIEW

The Keypad and PowerMate units should be inspected for physical damage before installation. Any cracked, broken or bent items on either unit should be reported to your local dealer of DSSA for proper disposition.

Ensure all power is off by disconnecting the battery(s) from the system or de-energizing the battery switch.

Prepare the unit for installation by removing all packaging materials. Keypads must be mounted to a flat surface using a properly positioned cutout for the keypad connector pigtail. The keypad mounting studs should be secured through the panel using 10-32 UNF nut and lock-washer. Tighten the nuts to snug only.

Do NOT exceed torque ratings as advertised of 7 ± 1 in. lbs or 0.79 N.m as this will crack or deform the keypad, which will cause intermittent operation.

Connect the keypad pigtail Deutsch connector to the wire harness (wire harnesses are not provided by DSSA). They must be designed, manufactured and installed to meet the DSSA requirements as well as the specific design requirements of the application, for length, termination, wire size, etc. It is the installers responsibility to ensure this has been done to meet or exceed design specifications.

To mount the PowerMate, the unit must be installed in a dry, well ventilated space inside the vehicle cabin. The ambient temperature must not exceed 70°C. It is recommended that the PowerMate be mounted with the plugs facing in a downward direction or to the rear of the installation to minimise potential damage to the plugs, harness and studs.

Secure the PowerMate with four bolts, nuts and washers or equivalent wood screws (not provided).

Secure the negative power side terminal to the negative power lug and secure with the nut and washer provided. Secure the positive power side terminal to the positive power lug and secure with the nut and washer provided. Take care to never reverse the terminal connections or reverse the order of connection.

Do NOT exceed recommended torque ratings as advertised of 12 ± 3 in. lbs or 1.36 N.m. Over tightening will cause the lug nut to crack or fail.

The main battery supply to the PowerMate must be protected by a switchable circuit breaker positioned at the battery. This enables the PowerMate to be isolated from the battery in the event of charging or changing the battery(s).

The PowerMate 15 Gen3 is limited to a maximum voltage supply of 30 volts.

Plug Deutsch connectors (ensuring the correct key is selected) and then apply battery power. The system is now ready for power and operation. Re-connect the main battery(s) to the circuit and follow the operational instructions below.

GENERAL FUNCTION

When a button on the keypad is pressed, the circuit for that button will turn on. The indicators on all keypads for that circuit will light up to show circuit is on. Any DSSA Keypad can turn a circuit ON or OFF.

If a circuit draws more than the rated current, the circuit will be turned OFF and the indicator LED will flash to indicate circuit was Tripped, To REST the circuit, Press and Hold the Keypad button down for 6 seconds.

The system will also detect and indicate faulted circuits. A faulted circuit can be wither an open circuit such as a defective device (burnt out bulb) or dead short circuit. When an Output fails, the operator can Press and Hold the Keypad button with the Flashing LED for 6 seconds, to REST the Output. The Output can now be tried again.

REMOVAL

To un-install the PowerMate from the system, the steps taken should be the reverse of the installation sequence.

Do NOT disconnect the power terminals while the Deutsch connectors are still attached.

Failure to disconnect the Deutsch connectors first, may cause the PowerMate to receive reverse current causing failure of the unit and voiding any warranties.

SPECIFICATIONS

MECHANICAL & ENVIRONMENTAL

Operating Temperature	-20 to +70°C
IP Rating	IP56
Weight	1081g
PowerMate Receptacles	Deutsch 4x DTF13-12P, 3x Studs (2x Battery, 1x Ground)
PowerMate Connector Plugs	Deutsch 4 x DT06-12S (1x A, 1x B, 1x C, & 1x D)

DIMENSIONS

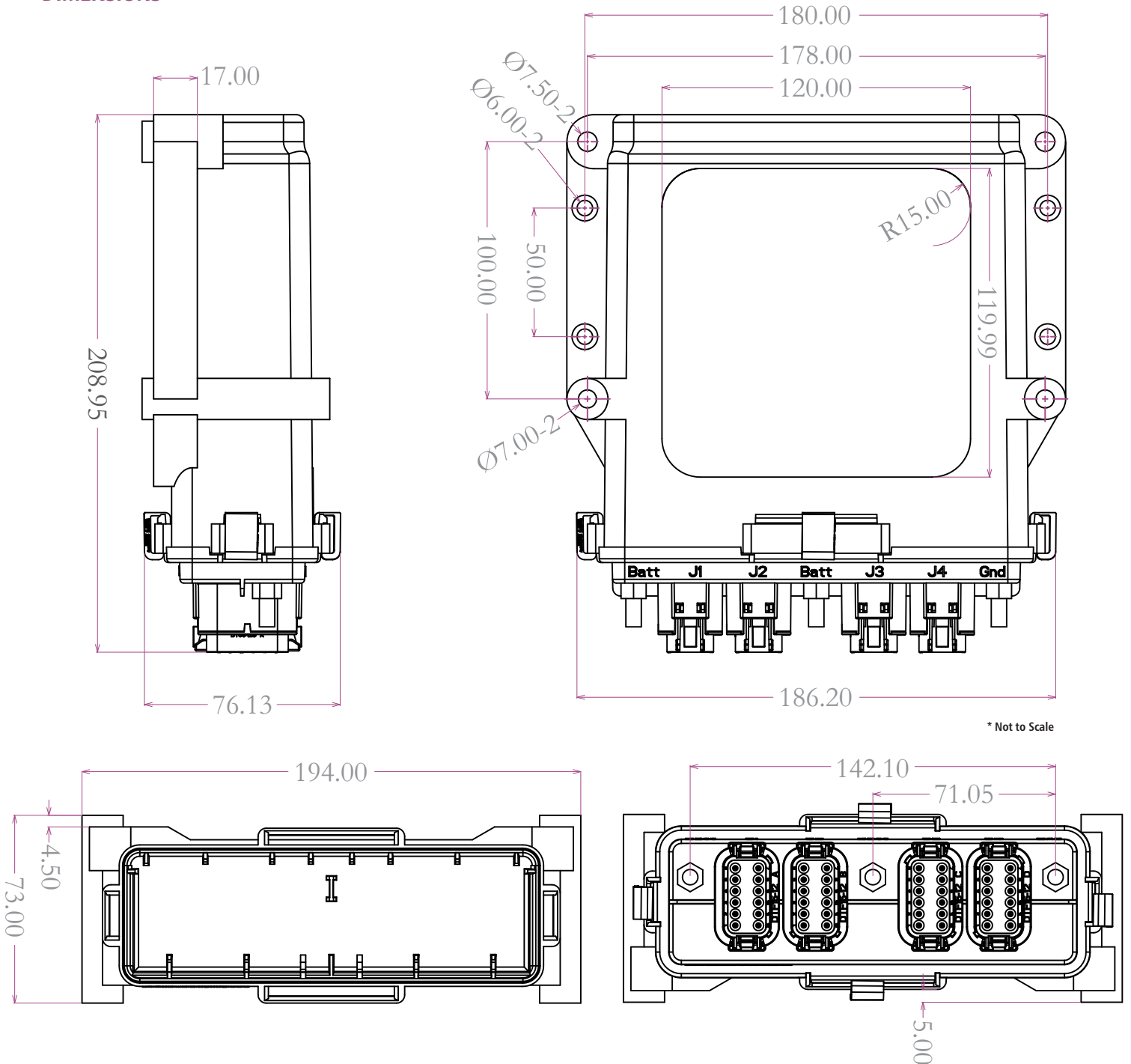

KEYPAD FUNCTIONS

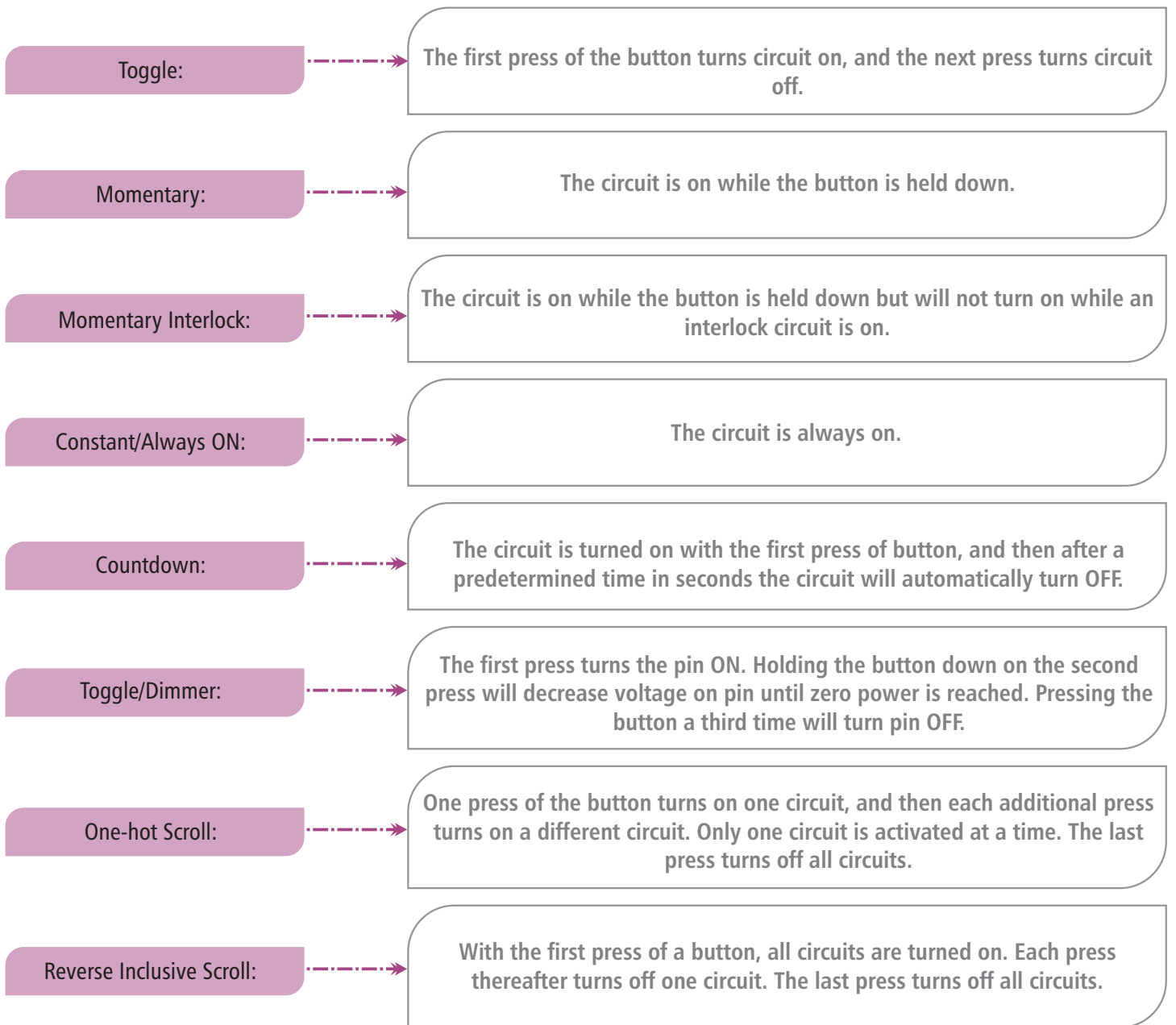

CONNECTION DIAGRAM

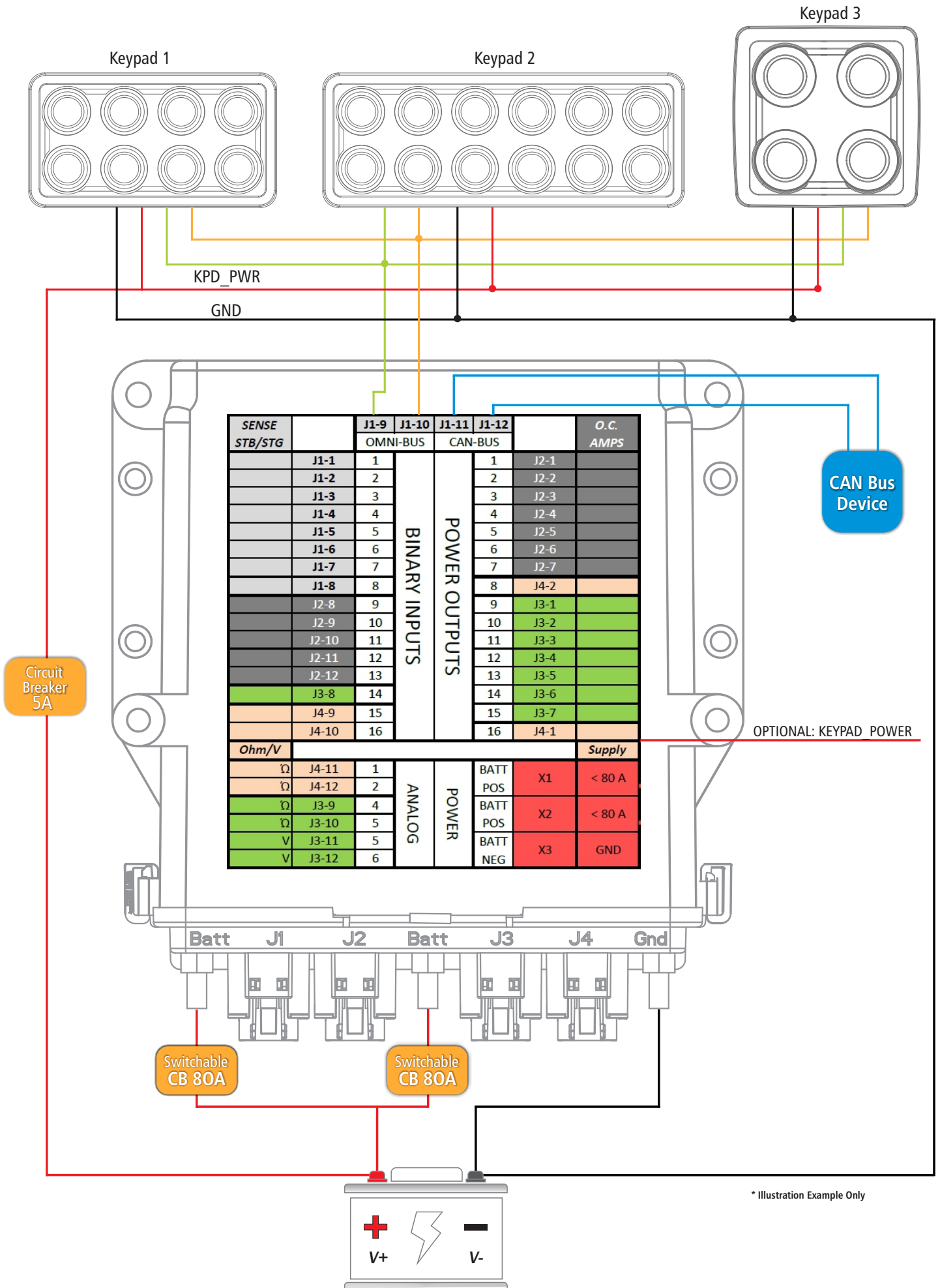

TROUBLESHOOTING

PROBLEM	POSSIBLE CAUSES	TROUBLESHOOTING STEPS
NO POWER TO KEYPADS (NO FUNCTIONS WORK AND NO LIGHTS TURN ON)	<ol style="list-style-type: none"> 1. Keypad not wired/connected properly 2. Low Battery Power 3. Faulty Keypad 	<ol style="list-style-type: none"> 1. Verify Keypad is wired to the battery properly 2. Verify battery is charged 3. Replace Keypad
WRONG OUTPUT IS ACTIVATED WHEN BUTTON IS PRESSED	<ol style="list-style-type: none"> 1. Improper Wiring 	<ol style="list-style-type: none"> 1. Verify Output Device is connect to appropriate PowerMate Output Pin
KEYPAD POWERS UP BUT NO FUNCTIONS WORK	<ol style="list-style-type: none"> 1. Tripped circuit limits 2. Improper Wiring 3. Faulty Keypad 4. Faulty PowerMate 	<ol style="list-style-type: none"> 1. Check Device for Over-Current 2. Verify communication lines (TX/RX+ and TX/RX-) are wired to appropriate PowerMate Pin #'s 3. Cycle Power to the Keypad and Watch
CIRCUIT IS ALWAYS TRIPPED WHEN BUTTON IS PRESSED (INDICATOR BLINKS AND WILL RESET AFTER 6 SECONDS WHEN KEY IS PRESSED)	<ol style="list-style-type: none"> 1. Faulty Output Device 2. Short Circuit in Wiring Harness 3. Circuit Trip limit value too low for Device 	<ol style="list-style-type: none"> 1. Verify Output Device is working properly 2. Check for Short Circuit in Wiring Harness 3. Verify Circuit Breaker value is sufficient for System
INDICATOR LED'S FLICKER ON AND OFF	<ol style="list-style-type: none"> 1. Function has No Load 2. Stray Voltage from Harness 	<ol style="list-style-type: none"> 1. Apply Load to the Function 2. Check Shielding on Communication Lines
SYSTEM LOCKS UP	<ol style="list-style-type: none"> 1. Low Battery Power 	<ol style="list-style-type: none"> 1. Cycle Power to the Keypad and PowerMate 2. Verify System is at Recommended Voltage

REVISION HISTORY

DATE	REVISION	COMMENTS
21/05/2018	1.0	Preliminary
20/05/2019	1.1	Draft Corrections
10/09/2019	1.2	Updated Installation of PM15 Gen3

