

REVISIONS				
ZONE	REV.	DESCRIPTION	DATE	APPROVED
	A	INITIAL RELEASE	6/21/2021	JAKE JANOSO

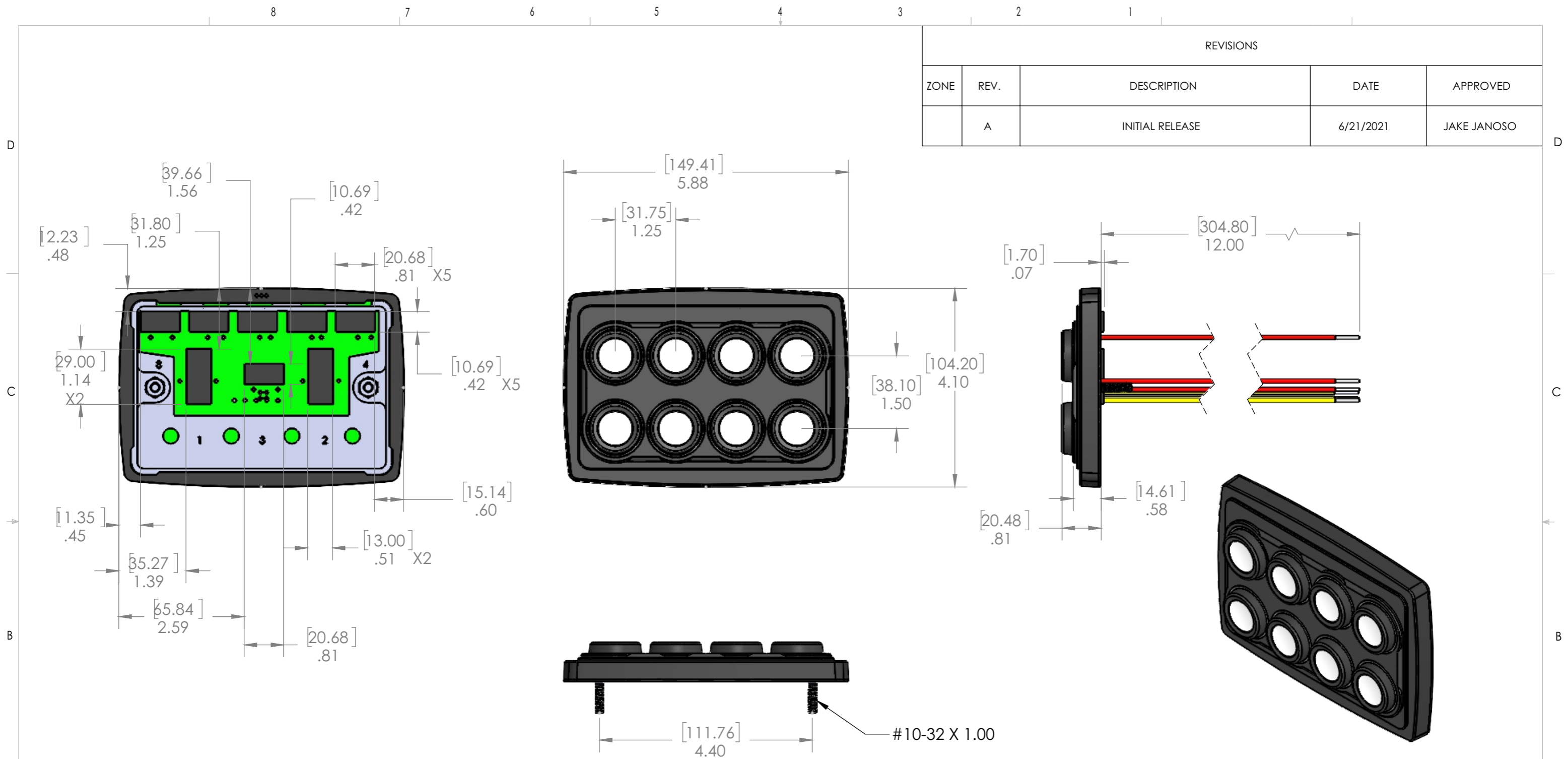

REVISION(S) PER ECN #:	UNLESS OTHERWISE SPECIFIED:	NAME	DATE	Googolplex Electric Co.
ECN DESCRIPTION:	DIMENSIONS ARE IN INCHES [MM] TOLERANCES: FRACTIONAL ± ANGULAR: MACH ± BEND ± TWO PLACE DECIMAL ±0.01 THREE PLACE DECIMAL ±0.005	DRAWN CHECKED ENG APPR. MFG APPR.	JAJ 	
PROPRIETARY AND CONFIDENTIAL THE INFORMATION CONTAINED IN THIS DRAWING IS THE SOLE PROPERTY OF GEC. ANY REPRODUCTION IN PART OR AS A WHOLE WITHOUT THE WRITTEN PERMISSION OF GEC IS PROHIBITED.	INTERPRET GEOMETRIC TOLERANCING PER:	Q.A.	TITLE: PKR2400 BUTTON SPACING	
	MATERIAL	COMMENTS:	SIZE B	DWG. NO. PKR2400
	FINISH		REV A	
	DO NOT SCALE DRAWING		SCALE: 1:2	WEIGHT: 455g
			SHEET 1 OF 1	

REVISIONS			
REV.	DESCRIPTION	DATE	APPROVED
A	INITIAL RELEASE	2/8/2018	JUSTIN HALL
B	ADDED TEMPLATE NOTE	7/28/2020	JAKE JANOSO

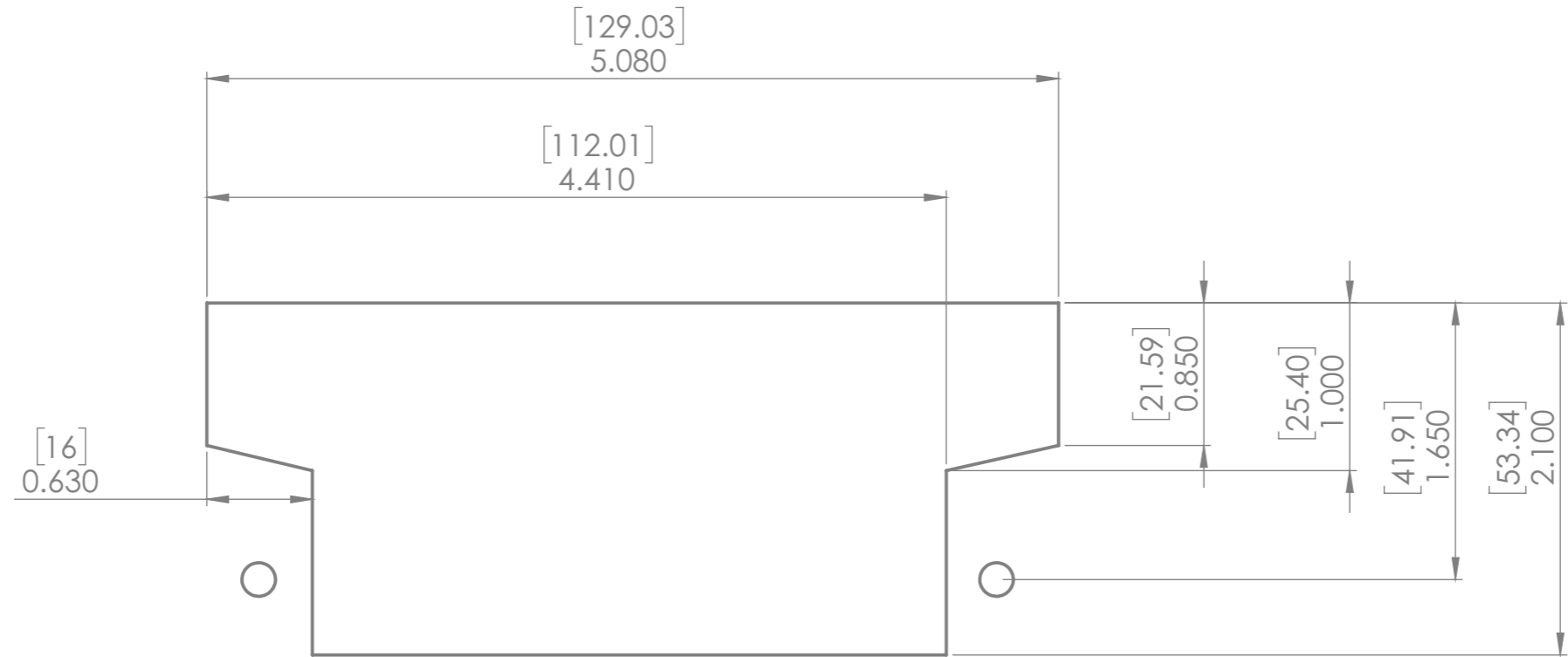

UNLESS OTHERWISE SPECIFIED:	NAME	DATE
DIMENSIONS ARE IN INCHES	DRAWN	JRH
TOLERANCES:	CHECKED	
FRACTIONAL ±	ENG APPR.	
ANGULAR: MACH ±1 BEND ±1	MFG APPR.	
TWO PLACE DECIMAL ±.01	Q.A.	
THREE PLACE DECIMAL ±.005	COMMENTS:	
INTERPRET GEOMETRIC TOLERANCING PER:		
MATERIAL		
FINISH		
DO NOT SCALE DRAWING		

Googolplex Electric Co.		
TITLE:		
PKR2400 CUTOUT		
SIZE	DWG. NO.	REV
A	PKR2400	B
SCALE: 1:1	WEIGHT: 455g	SHEET 1 OF 2



PROPRIETARY AND CONFIDENTIAL
 THE INFORMATION CONTAINED IN THIS DRAWING IS THE SOLE PROPERTY OF GEC. ANY REPRODUCTION IN PART OR AS A WHOLE WITHOUT THE WRITTEN PERMISSION OF GEC IS PROHIBITED.

5 4 3 2 1

REVISIONS				
ZONE	REV.	DESCRIPTION	DATE	APPROVED
-	-	See Sheet1	-	-



TEMPLATE NOTE: ALL DIMENSIONS ARE 1:1
PLEASE VERIFY SCALING PRIOR TO DRILLING



PROPRIETARY AND CONFIDENTIAL
THE INFORMATION CONTAINED IN THIS DRAWING IS THE SOLE PROPERTY OF GEC. ANY REPRODUCTION IN PART OR AS A WHOLE WITHOUT THE WRITTEN PERMISSION OF GEC IS PROHIBITED.

UNLESS OTHERWISE SPECIFIED:	NAME	DATE
DIMENSIONS ARE IN INCHES	DRAWN	JRH
TOLERANCES:	CHECKED	5/19
FRACTIONAL ±	ENG APPR.	
ANGULAR: MACH ±1 BEND ±1	MFG APPR.	
TWO PLACE DECIMAL ±.01	Q.A.	
THREE PLACE DECIMAL ±.005	COMMENTS:	
INTERPRET GEOMETRIC TOLERANCING PER:		
MATERIAL		
FINISH		
DO NOT SCALE DRAWING		

Googolplex Electric Co.

TITLE:

PKR2400 CUTOUT

SIZE	DWG. NO.	REV
A	PKR2400	B

SCALE: 1:1 WEIGHT: 455g SHEET 2 OF 2

5

4

3

2

1

PKR2400 DIMENSIONS

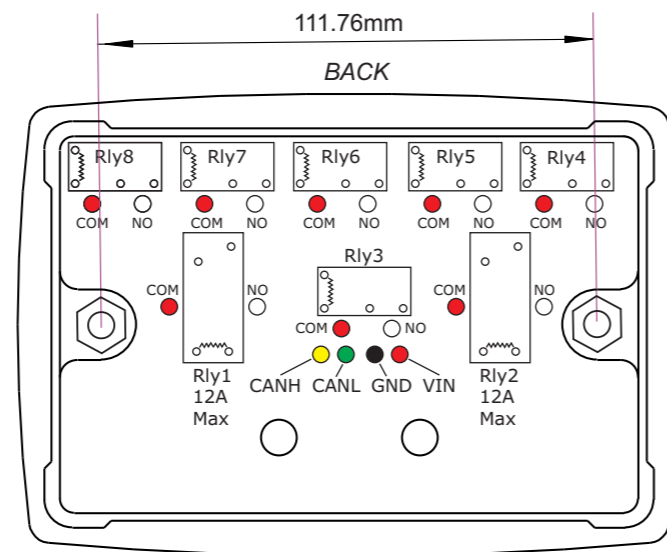
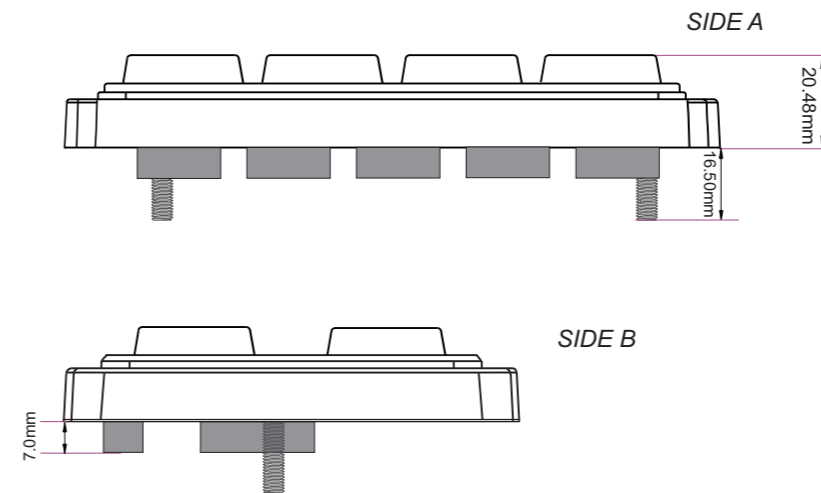
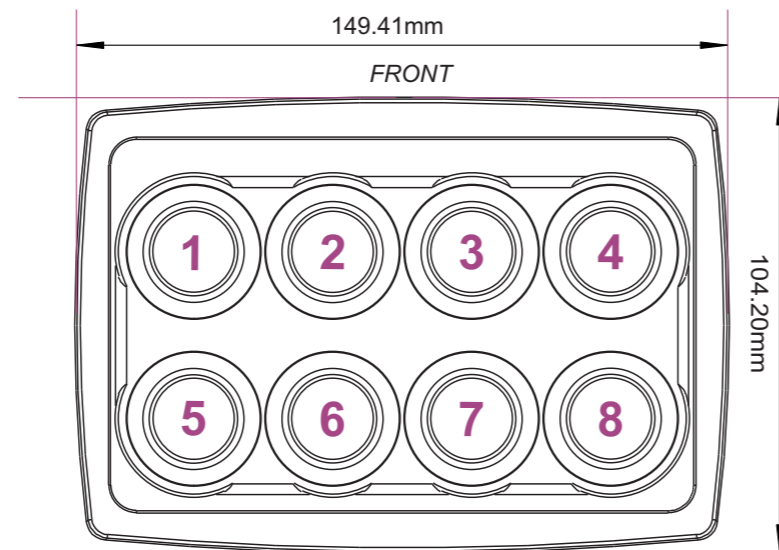

*Diagrams are NOT to Scale

MOUNT ON A FLAT SURFACE ONLY

Part Number:	GEC-PKR2400
Weight:	455g
Nut Size*:	10-32 UNF S/S
Washer Sizes:	M5 Spring Washer S/S, M5 Flat Washer S/S
Torque Mounting Nuts:	7 +/- 1 in. lbs

*DO NOT USE NYLOC NUTS

 Gogolplex Electric Co.

Unit 3/15 Parramatta Road, Underwood QLD, AUSTRALIA 4119

PO Box 1301, Slacks Creek QLD, AUSTRALIA 4127

P +61 (0)7 3290 3116

E sales@gogolplex.com.au

W www.gogolplex.com.au