



## When Safety Matters

The Park Brake Alarm is a safety device intended as an audible warning system to alert both the driver and any personal in the general area when the Park Brake has not been applied.

This simple but intelligent device constantly observes both the Door Switch and Park Brake Switch signals. If the Cabin Door is OPENED and the Park Brake has NOT been APPLIED, the device will instantaneously sound both the module Alarm and the vehicle Horn.

The vehicle Horn will continue to sound even when the Cabin Door has been closed (applying the Park Brake will immediately DISABLE both Alarm and Horn notifications).

The Park Brake Alarm device also has an optional connection, where the module Alarm will sound for 2 seconds BEFORE the vehicle Horn is sounded. This function sounds as a warning to the driver as a reminder to APPLY the Park Brake.

The compact, sealed and maintenance free device has the added benefit of being multi-voltage (12-24DC).

With hassle free installation the Park Brake Alarm is an excellent economical safety device.

## DIMENSIONS

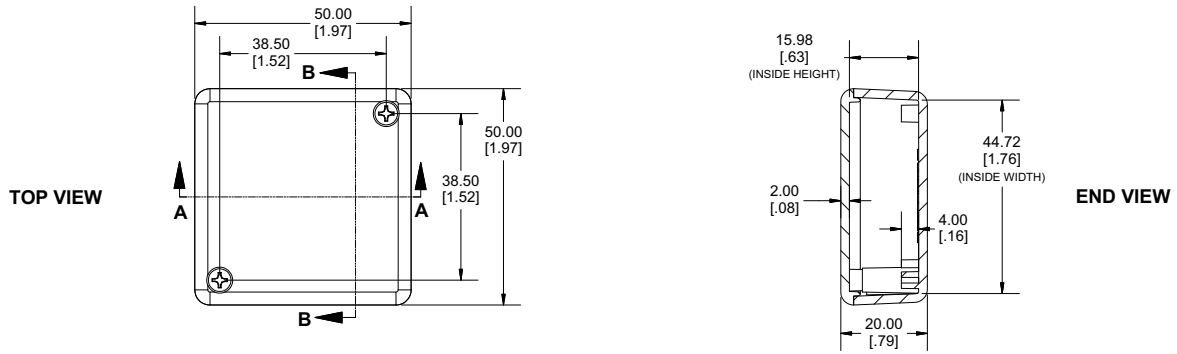

## INSTALLATION

The installer needs to connect the Door Switch Signal and Park Brake Signal onto the Park Brake Alarm in order for the Park Brake Alarm to function correctly.

Separate Inputs are provided for High Active and Low Active Input, the end user needs only to select and connect one of them.

## WIRING

Red	B+	Battery Positive	+9 to 32V
Black	B-	Battery Negative	
Green	Prk.Br.L	Park Brake Switch Input	Active Low
Orange	Prk.Br.H	Park Brake Switch Input	Active High
Brown	Dr.Sw.L	Door Switch Input	Active Low
Dark Blue	Dr.Sw.H	Door Switch Input	Active High
Yellow	Ex.Buzzer.1	External Output 2 (Output to energise Horn Relay) 2 Sec Delay	Switch to Ground
White	Ex.Buzzer.2	External Output 2 (output to energise Horn Relay) No Delay	Switch to Ground

## TYPICAL CONNECTION

\* For installation purposes please download the wiring diagram

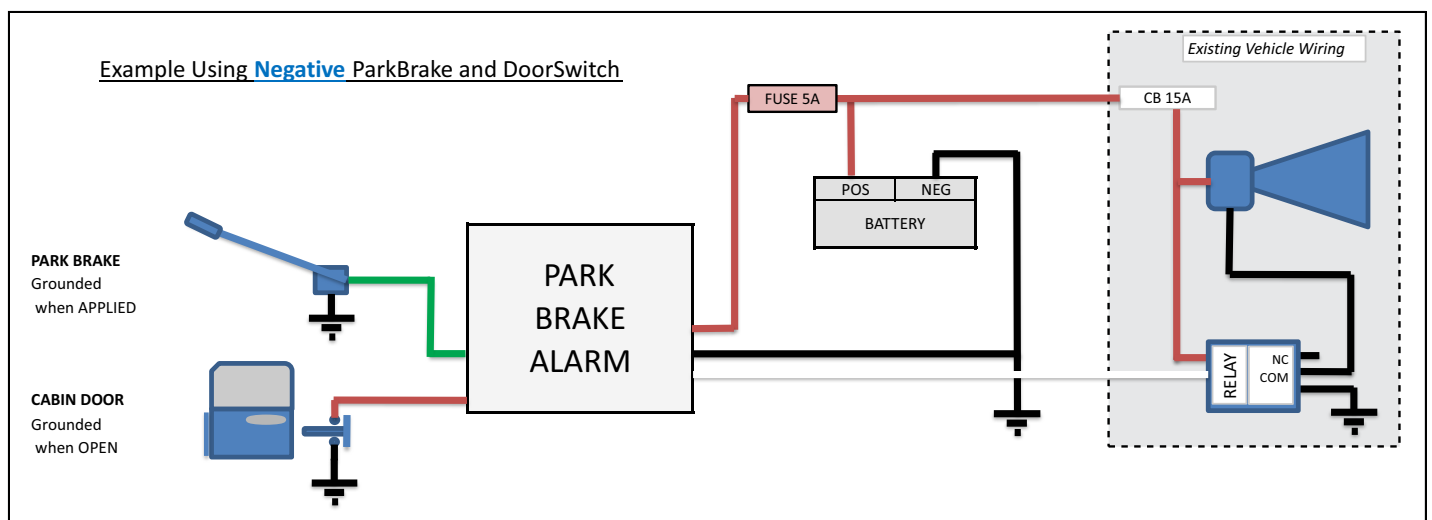

PBA WIRING (2)